



PHI-CON

6 W DC-DC Converter P6E-Series

- SIL 8 Pin
- Wide input range 2:1
- 1500 V_{DC} isolation
- Optional 3000 V_{DC} isolation
- Continuous short circuit protection
- Remote control input



Model guide

Type	Input voltage		Input current no load [mA] typ.	Input current full load [mA] typ.	Output voltage [V _{DC}]	Output current min. [mA]	Output current max. [mA]	Efficiency @ full load [%] typ.	Capacitive load (see note 1) [μF] max.
	Nominal [V _{DC}]	Range [V _{DC}]							
Single output									
P6E053R3SC	5	4.5...9	105	1145	3.3	0	1300	75	6600
P6E0505SC	5	4.5...9	105	1520	5.0	0	1200	79	3300
P6E0509SC	5	4.5...9	105	1445	9.0	0	667	83	2000
P6E0512SC	5	4.5...9	105	1430	12.0	0	500	84	1600
P6E0515SC	5	4.5...9	105	1430	15.0	0	400	84	1400
P6E0524SC	5	4.5...9	105	1430	24.0	0	250	84	680
P6E123R3SC	12	9...18	55	470	3.3	0	1300	76	6600
P6E1205SC	12	9...18	55	600	5.0	0	1200	83	3300
P6E1209SC	12	9...18	55	595	9.0	0	667	84	2000
P6E1212SC	12	9...18	55	590	12.0	0	500	85	1600
P6E1215SC	12	9...18	55	590	15.0	0	400	85	1400
P6E1224SC	12	9...18	55	580	24.0	0	250	86	680
P6E243R3SC	24	18...36	30	230	3.3	0	1300	78	6600
P6E2405SC	24	18...36	30	300	5.0	0	1200	83	3300
P6E2409SC	24	18...36	30	295	9.0	0	667	85	2000
P6E2412SC	24	18...36	30	295	12.0	0	500	85	1600
P6E2415SC	24	18...36	30	285	15.0	0	400	87	1400
P6E2424SC	24	18...36	30	285	24.0	0	250	87	680
P6E483R3SC	48	36...75	15	115	3.3	0	1300	76	6600
P6E4805SC	48	36...75	15	155	5.0	0	1200	80	3300
P6E4809SC	48	36...75	15	145	9.0	0	667	85	2000
P6E4812SC	48	36...75	15	150	12.0	0	500	84	1600
P6E4815SC	48	36...75	15	145	15.0	0	400	86	1400
P6E4824SC	48	36...75	15	150	24.0	0	250	84	680
Dual output									
P6E0505DC	5	4.5...9	105	1480	±5.0	0	±600	81	2 x 2000
P6E0512DC	5	4.5...9	105	1430	±12.0	0	±250	84	2 x 900
P6E0515DC	5	4.5...9	105	1430	±15.0	0	±200	84	2 x 660
P6E1205DC	12	9...18	55	610	±5.0	0	±600	82	2 x 2000
P6E1212DC	12	9...18	55	595	±12.0	0	±250	84	2 x 900
P6E1215DC	12	9...18	55	580	±15.0	0	±200	86	2 x 660
P6E2405DC	24	18...36	30	305	±5.0	0	±600	82	2 x 2000
P6E2412DC	24	18...36	30	300	±12.0	0	±250	84	2 x 900
P6E2415DC	24	18...36	30	300	±15.0	0	±200	84	2 x 660
P6E4805DC	48	36...75	15	150	±5.0	0	±600	82	2 x 2000
P6E4812DC	48	36...75	15	145	±12.0	0	±250	85	2 x 900
P6E4815DC	48	36...75	15	145	±15.0	0	±200	85	2 x 660

Part number structure											
Output power	Series	Input voltage		Output voltage		Outputs		Isolation		Remote control	
P6	E	05		3R3		S		H		C	
6 Watt		05	4.5..9 V	3R3	3.3 V	S	single	Blank	1.5 kV	C	control Input
		12	9..18 V	05	5 V	D	dual	H	3 kV	Blank	without remote control function
		24	18..36 V	09	9 V						
		48	36..75 V	12	12 V						
				15	15 V						
				24	24 V						



PHI-CON

6 W DC-DC Converter P6E-Series

Specifications

Input	
Input reflected ripple current	30 mApp, typ. (see Figure 1)
Filter	Capacitors
On / Off controll pin	on: open off: 2...4 mA control current (via serial resistor 1 k Ω , see Figure 3)
Standby current consumption	2.5 mA typ.
Isolation:	
isolation voltage input / output (60 s)	1500 V _{DC} 3000 V _{DC} (Suffix "H")
Resistance	10 ⁷ Ω , min.
Capacitance	50 pF, max.
Output	
Voltage accuracy	± 1 %
Ripple and noise (at 20 MHz BW)	75 mVp-p, max. (see Figure 2)
Short circuit protection	Continuous
Short circuit restart	Automatic
Start up time	30 ms, typ.
Line voltage regulation	± 0.2 %
Load regulation	± 1 % (at 0...100 % load change)
Dual output cross regulation at 75 % load difference	± 5 %, max.
Temperature coefficient	± 0.02 % / °C
Transient recovery time at 25 % load change steps	500 μ s, typ.
Transient response deviation at 25 % load change steps	P6Exx3R3S ± 5 %, max. P6Exx05x ± 5 %, max. All others ± 3 %, max.

General		
Switching frequency	100 kHz, min.	
Safety standards	IEC-, EN-, UL-, ULc 60950-1 IEC-, EN-, UL-, ULc 62368-1	
Reliability calculated MTBF (MIL-HDBK-217F, 25 °C)	> 770000 h	
EMC specifications		
CE	EN 55032	Class A
RE	EN 55032	Class A (see Figure 4)
ESD	EN-, IEC 61000-4-2	Perf. criteria A
RS	EN-, IEC 61000-4-3	Perf. criteria A
EFT	EN-, IEC 61000-4-4	Perf. criteria A (see Figure 4)
Surge	EN-, IEC 61000-4-5	Perf. criteria A (see Figure 4)
CS	EN-, IEC 61000-4-6	Perf. criteria A
PfMF	EN-, IEC 61000-4-8	Perf. criteria A
Environmental		
Operating ambient temperature	-40 ... 65 °C	
Case operating temperature	105 °C, max.	
Storage temperature	-55 ... 125 °C	
Derating	See derating diagram	
Storage humidity	Up to 95 %, non condensing	
Cooling		
Physical		
Dimensions SIP8	21.85 x 9.2 x 11.1 mm	
Weight	4.5 g	
Case material	Non conductive plastic (UL94-V0 rated)	
Potting material	Epoxy (UL94-V0 rated)	
Absolute maximum ratings		
Absolute max. voltage for 100 ms	P6E05xxxx 15 V _{DC} P6E12xxxx 36 V _{DC} P6E24xxxx 50 V _{DC} P6E48xxxx 100 V _{DC}	
Pin soldering temperature	≤ 260 °C for ≤ 10 s, ≥ 1.5 mm distance from body	

Notes:

1. Maximum capacitive load is specified at minimal Vin and constant resistive load.
2. Free air convection is usually about 30...65 LFM but is not equal to still air.
3. All specifications are typical at 25 °C, nominal input voltage and full load unless otherwise noted.

Figure 1 Measure circuit Reflected input ripple current

Input reflected current is measured through a source inductor and a source capacitor at nominal input voltage and full load.

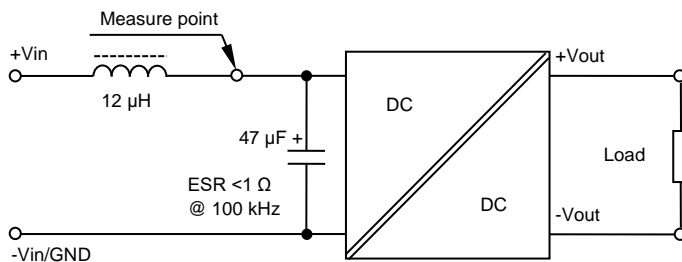

6 W DC-DC Converter P6E-Series

Figure 2 Measure circuit output ripple & noise voltage

Use the following measurement circuit. The oscilloscope measurement bandwidth 20 MHz.

Single output

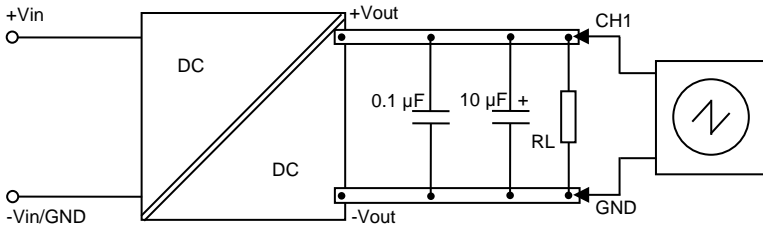

Dual output

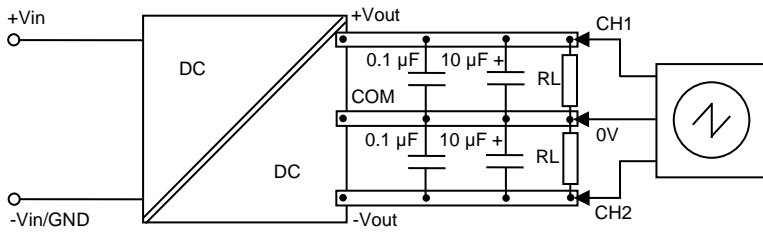

Figure 3 Application circuit for remote control function

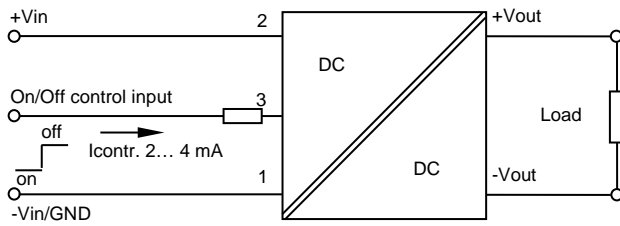
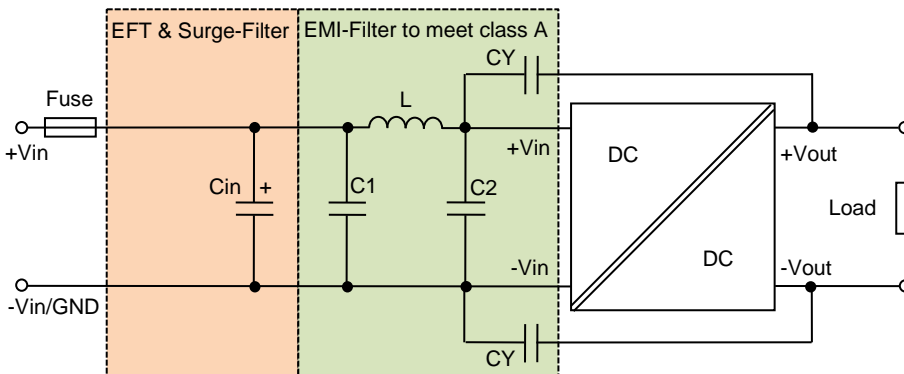

Figure 4 Application circuit EMI Filter for EN 55032 class A

The filter components are used to help meet conducted emissions requirement for the module. These components should be closed mounted as possible to the module. All leads should be minimized to decrease radiated noise.



BOM for Figure 4				
Type	Cin	C1, C2	CY	L
P6E05xxxx	330 µF	22 µF, 25 V, MLCC	220 pF / 3 kV	10 µH
P6E12xxxx	330 µF	10 µF, 50 V, MLCC	220 pF / 3 kV	10 µH
P6E24xxxx	330 µF	10 µF, 50 V, MLCC	220 pF / 3 kV	10 µH
P6E48xxxx	330 µF	2.2 µF, 100 V, MLCC	220 pF / 3 kV	10 µH

6 W DC-DC Converter P6E-Series

Derating diagram

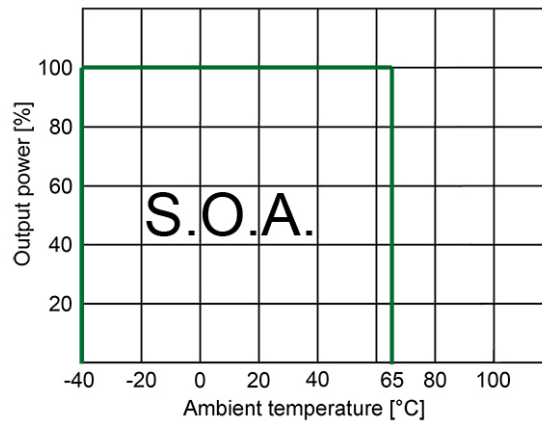

Mechanical dimensions

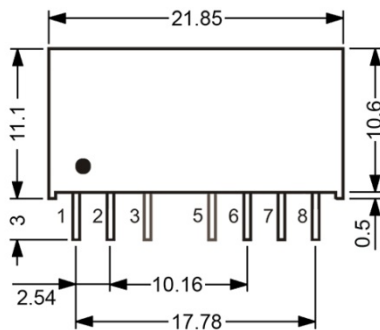

All units in mm

1. Pin diameter tolerance ± 0.05 mm
2. Pin pitch tolerance ± 0.35 mm
3. Pin length tolerance ± 0.35 mm
4. Pin to case tolerance ± 0.5 mm
5. Stand off tolerance ± 0.1 mm

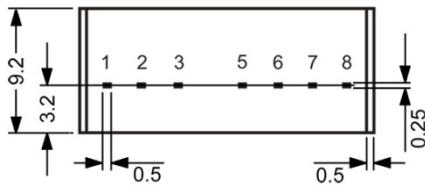

Pin assignment				
Pin	Single	Single with Rem.-Ctrl.	Dual	Dual with Rem.-Ctrl.
1	-V Input	-V Input	-V Input	-V Input
2	+V Input	+V Input	+V Input	+V Input
3	No Pin	Remote contr. on/off	Not connected	Remote contr. on/off
5	No Pin	Not connected	Not connected	Not connected
6	+V Output	+V Output	+V Output	+V Output
7	-V Output	-V Output	Common	Common
8	Not connected	Not connected	-V Output	-V Output

PHI-CON is a trademark of HY-LINE Holding GmbH.

Only for professional use by professionals! Not for resale or distribution to the general public in any way! Read the instructions carefully before using!

Life Support Policy: HY-LINE does not authorize the use of any of its products for use in life support devices or systems without the express written approval of an officer of the Company. Life support systems are devices which support or sustain life, and whose failure to perform, when properly used in accordance with instructions for use provided in the labeling, can be reasonably expected to result in significant injury to the user.

Rev: 20200206 f