



PHI-CON

# 1 W DC-DC Converter P1OS-Series

- Single output
- Dual output
- Up to 4200 V<sub>DC</sub> isolation
- Working voltage 250 V<sub>rms</sub>
- MTBF > 7 Mio. h at 25 °C
- -40...105 °C Operating temperature range
- Efficiency up to 78 %



SMD8

SMD10

## Model guide

Type	Input voltage		Output voltage [V <sub>DC</sub> ]	Input current		Output current max. [mA]	Efficiency [%] typ.	Capacitive load [μF] max.	Design
	Nominal [V <sub>DC</sub> ]	range [V <sub>DC</sub> ]		No load [mA] typ.	Full load [mA] typ.				
P1OS3R33R3S	3.3	2.97...3.63	3.3	50	420	300	73	220	SMD8
P1OS3R305S	3.3	2.97...3.63	5.0	50	410	200	75	220	SMD8
P1OS053R3S	5	4.5...5.5	3.3	40	280	300	73	220	SMD8
P1OS0505S	5	4.5...5.5	5.0	40	270	200	76	220	SMD8
P1OS3R33R3D	3.3	2.97...3.63	±3.3	50	405	±151	75	2 x 100	SMD10
P1OS3R305D	3.3	2.97...3.63	±5.0	50	395	±100	78	2 x 100	SMD10
P1OS053R3D	5	4.5...5.5	±3.3	40	280	±151	75	2 x 100	SMD10
P1OS0505D	5	4.5...5.5	±5.0	40	270	±100	78	2 x 100	SMD10

## Specifications

Input	
Voltage range	± 10 %
Filter	Capacitor
Reflected input ripple current	20 mA <sub>p-p</sub> , typ. (see Figure 1)
Start up time	20 ms, typ.
Input / output:	
Isolation voltage 60 s qualified, 100 % endtest for 3 s	≥ 4.2 kV <sub>DC</sub>
Isolation Resistance	≥ 10 <sup>9</sup> Ω
Capacitance	25 pF, typ.
Output	
Output voltage drift @ input voltage change	± 1.2 % @ 1% V <sub>in</sub> change
Output voltage tolerance at load range 10...100 %	P1OSxx3R3x: ±15%, max P1OSxx05x: ±12%, max
Output voltage deviation @ 10 % to 100 % load change	See diagrams
Temperature coefficient	0.03 % / °C
Short circuit	0.5 s, max., automatic restart
Ripple & noise at BW 0..20 MHz	Single output types: 150 mV Dual output types: 120 mV (see Figure 2)
General	
Switching frequency	50 kHz ... 80 kHz
Safety standard	UL-, cUL-, IEC-, EN 60950-1 UL-, cUL-, IEC-, EN 62368-1

Environmental		
EMI CE	EN 55032	Class B (see Figure 3)
EMI RE	EN 55032	Class B
ESD	IEC 61000-4-2	Perf. criteria A
RS	IEC 61000-4-3	Perf. criteria A
EFT	IEC 61000-4-4	Perf. criteria A (see Figure 3)
Surge	IEC 61000-4-5	Perf. criteria A (see Figure 3)
CS	IEC 61000-4-6	Perf. criteria A
PFMF	IEC 61000-4-8	Perf. criteria A
Operating ambient temperature	-40 ... 105 °C see derating SOA	
Storage temperature	-55 ... 125 °C	
Humidity	Up to 95 %, non condensing	
Cooling	Free air convection, 30...65 LFM	
Physical		
Basic material	UL94V-0 rated	
Weight	SMD8: 1.52 g (single output) SMD10: 1.8 g (dual output)	
Vibration	MIL-STD-810F	
Reliability calculated, MTBF (MIL-HDBK-217 @ 25 °C)	≥ 7 Mio. h	
Absolute maximum ratings		
Input voltage P1OS03xxx	≤ 5 V <sub>DC</sub> , duration ≤ 1s	
Input voltage P1OS05xxx	≤ 9 V <sub>DC</sub> , duration ≤ 1s	
Reflow soldering temperature	≤ 217 °C duration ≤ 60 s ≤ 245 °C peak ≤ 10 s	
Moisture sensitivity (MSL1)	IPC/JEDEC J-STD-020D.1	

Note:

- All parameter are specified at 25°C ambient temperature, resistive full load and nominal input voltage, if not otherwise specified.
- These converters are not suitable for IGBT applications.
- These converters are not suitable for water washing process.
- Capacitive load is specified at minimum input voltage and resistive full load.

## Ordering information

PHI-CON & output power		Series designation	Mounting technology	Input voltage		Output voltage		Output configuration		Packing		
P1	1 W	O	S	SMT	3R3	3.3V	3R3	3.3V	S	Single	blank	Tube
					05	5 V	05	5 V	D	Dual	TR	Reel

Figure 1 Input ripple current measure circuit

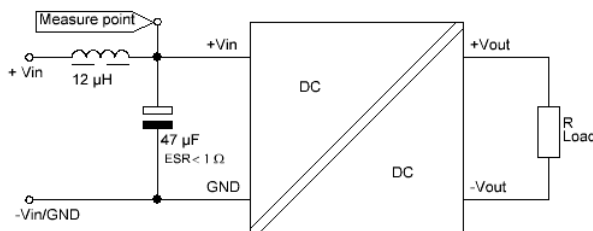

# 1 W DC-DC Converter P1OS-Series

Figure 2 Output ripple & noise measure circuit (measure bandwidth 0...20 MHz)

Single output

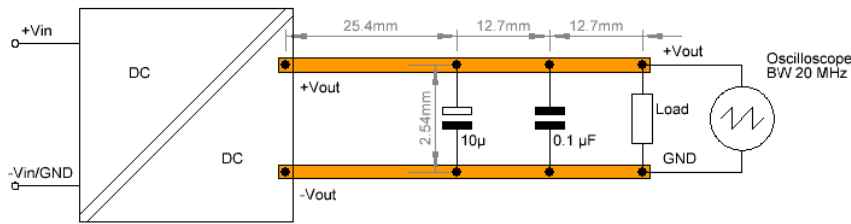

Dual output

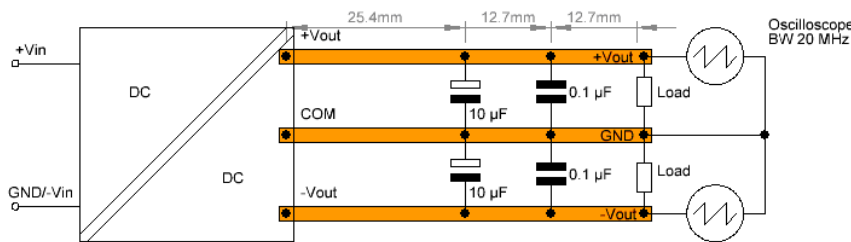
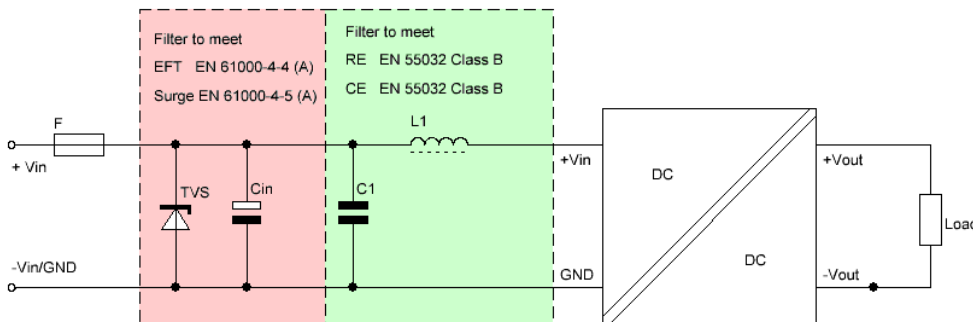
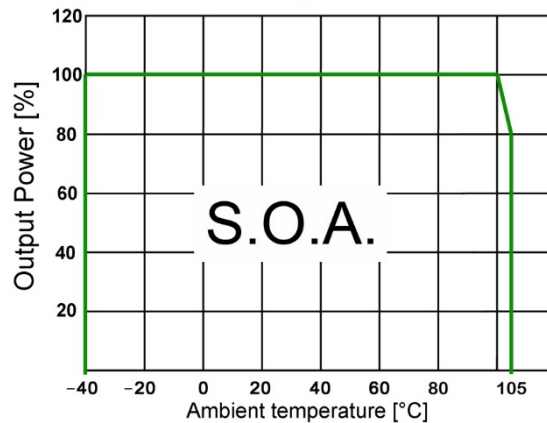

Figure 3 Output ripple & noise measure circuit



Type	Recommended Input fuse	EFT&Surge Filter		EMC Filter	
	F	TVS	Cin	C1	L1
P1OS3R3xxS	1 A, time delayed type	SMDJ6.0A	330 µF, 35 V	22 µF, 10 V <sub>DC</sub> , MLCC	6.8 µH
P1OS05xxS	0.5 A, time delayed type	SMDJ9.0A	330 µF, 35 V	22 µF, 10 V <sub>DC</sub> , MLCC	6.8 µH

## Derating Curve



# 1 W DC-DC Converter P1OS-Series



PHI-CON

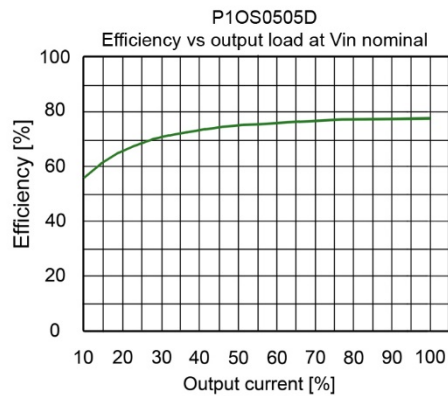
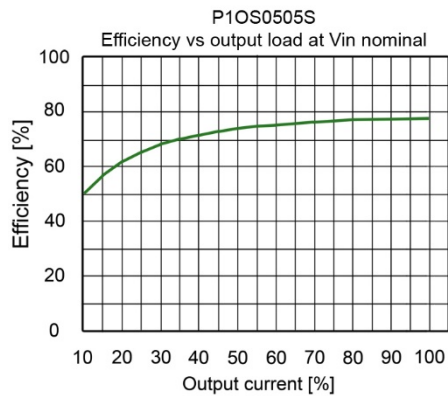
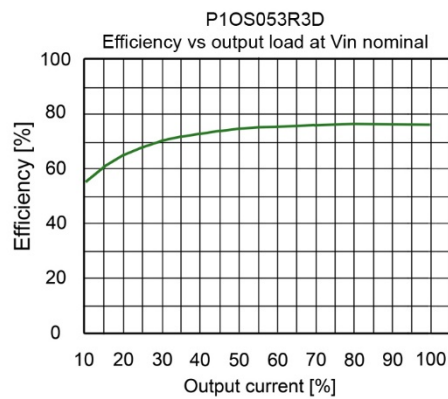
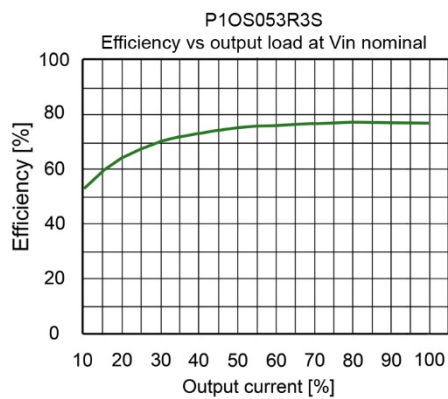
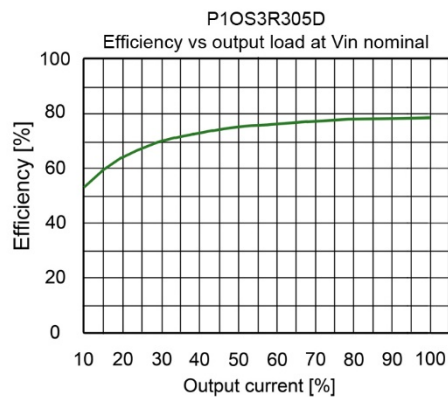
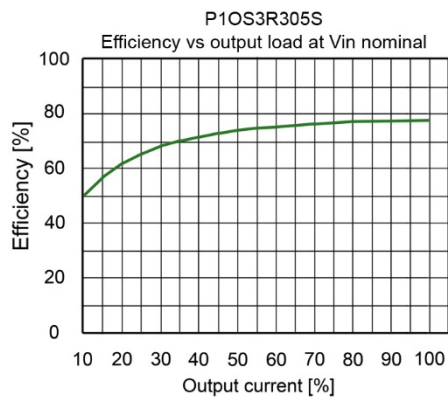
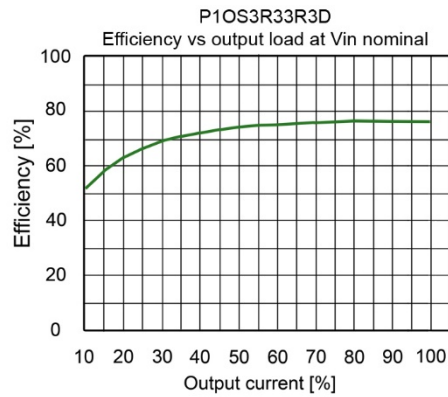
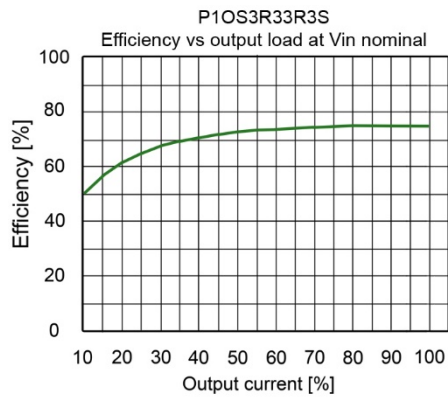



PHI-CON

# 1 W DC-DC Converter P1OS-Series

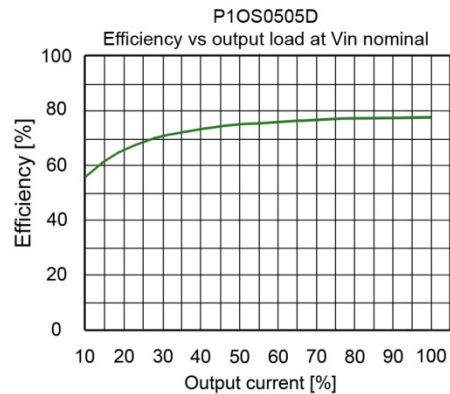
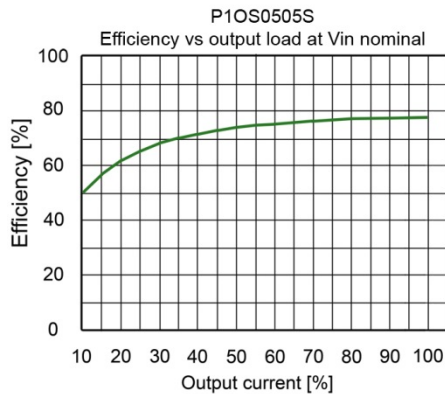
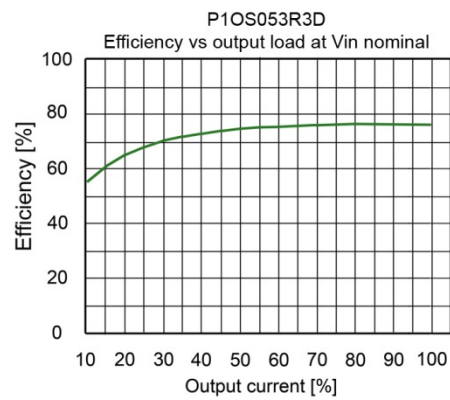
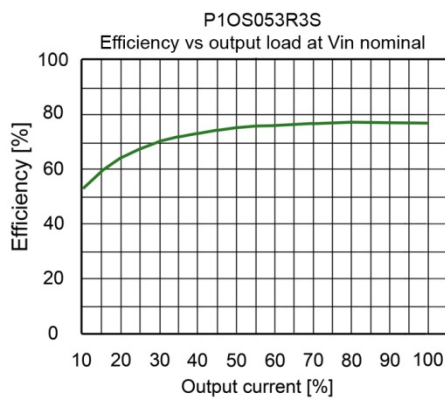
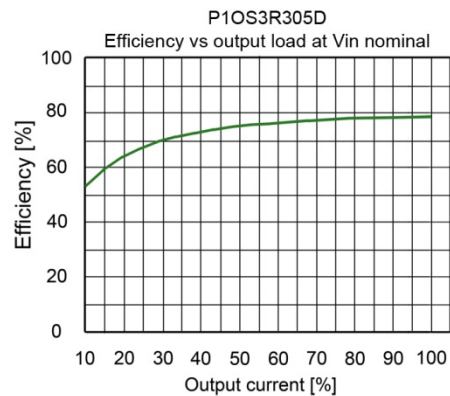
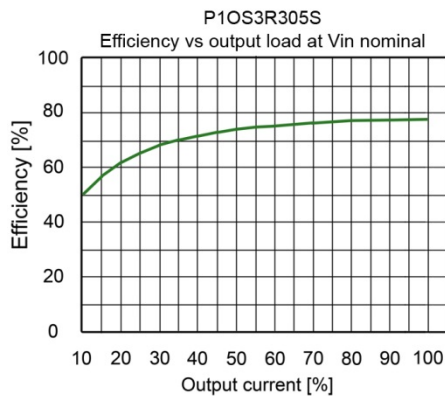
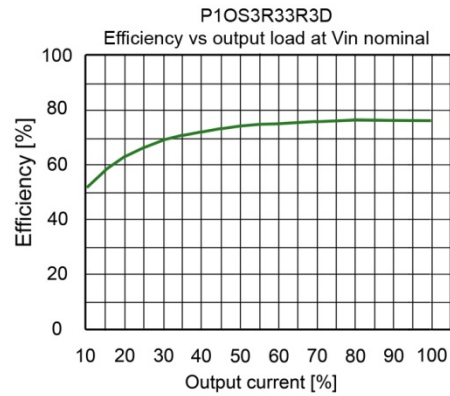
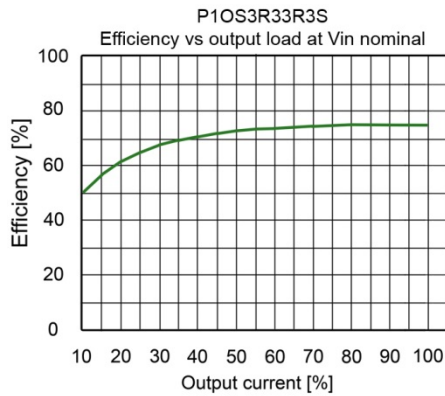



PHI-CON

# 1 W DC-DC Converter P1OS-Series

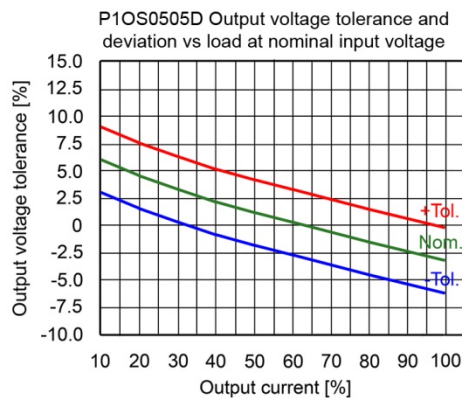
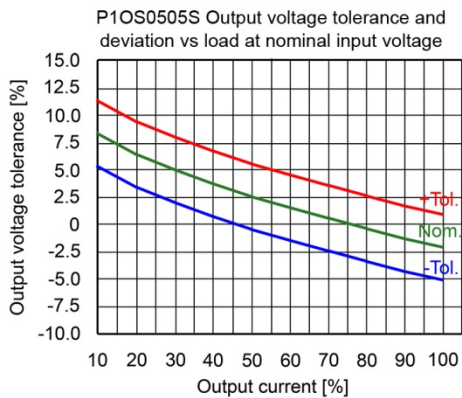
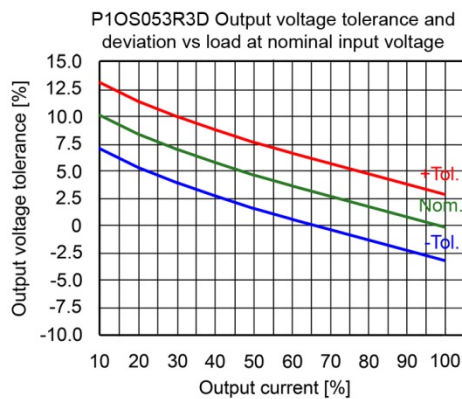
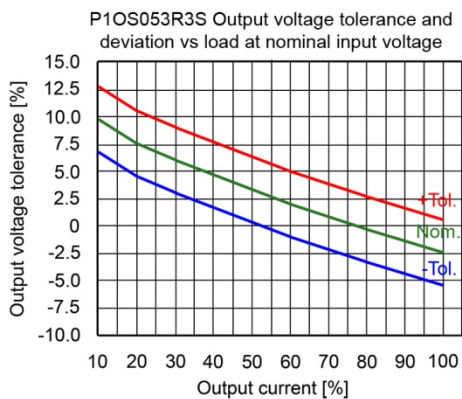
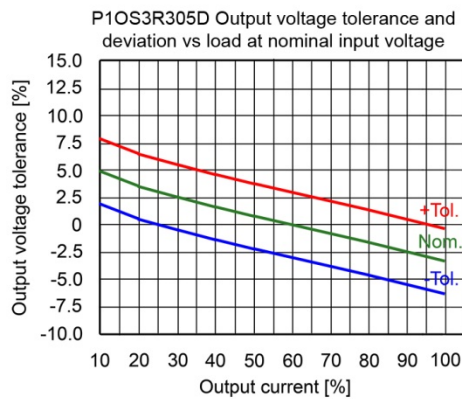
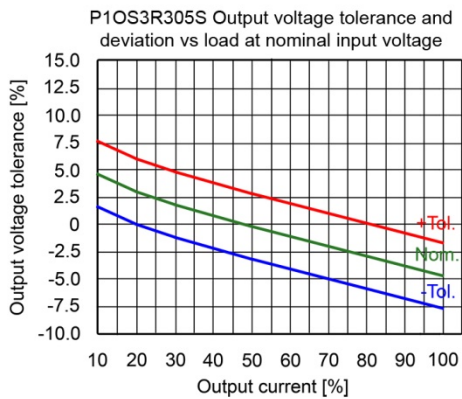
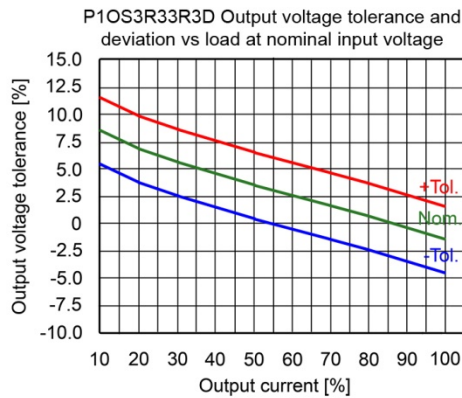
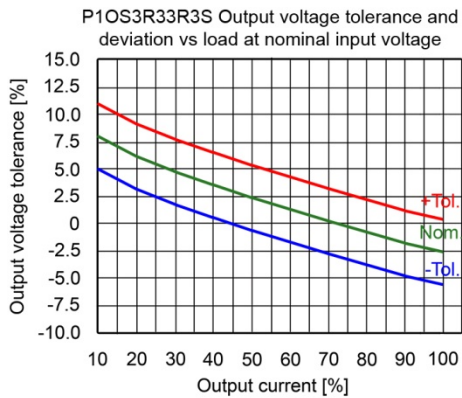



PHI-CON

# 1 W DC-DC Converter P10S-Series

Mechanical dimensions SMD8

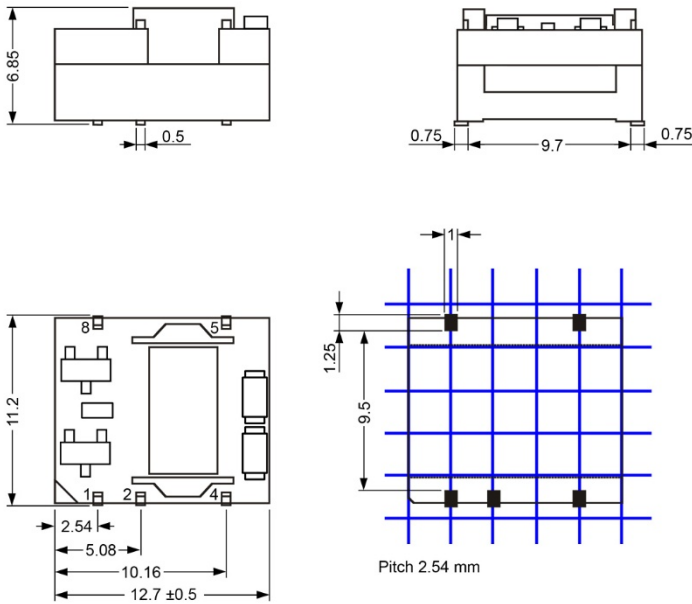

Assignment single output	
Lead	Function
1	-Vinput
2	+Vinput
3	No Lead
4	-Voutput
5	+ Voutput
6	No Lead
7	No Lead
8	Not connected

All dimensions in mm  
 Generell tolerances 0.25 mm  
 SMD8 packing units:  
 Tube 40 pieces  
 Tape & Reel 500 pieces

Mechanical dimensions tape 24 mm for SMD8 package

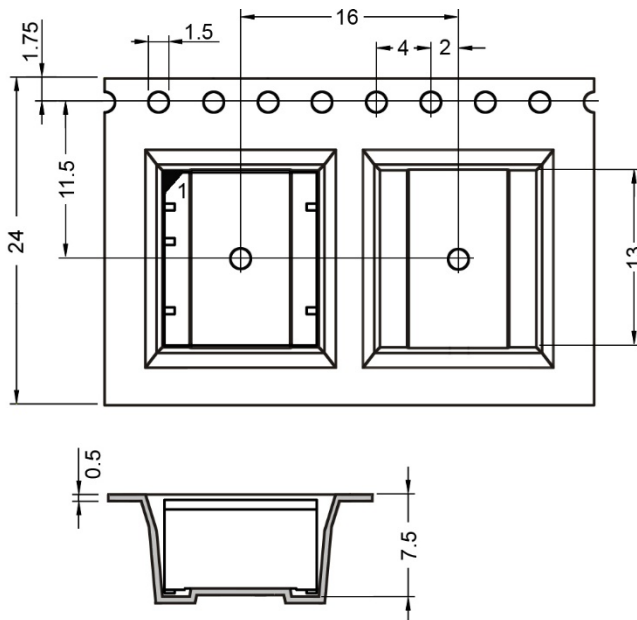



PHI-CON

# 1 W DC-DC Converter P10S-Series

Mechanical dimensions SMD10

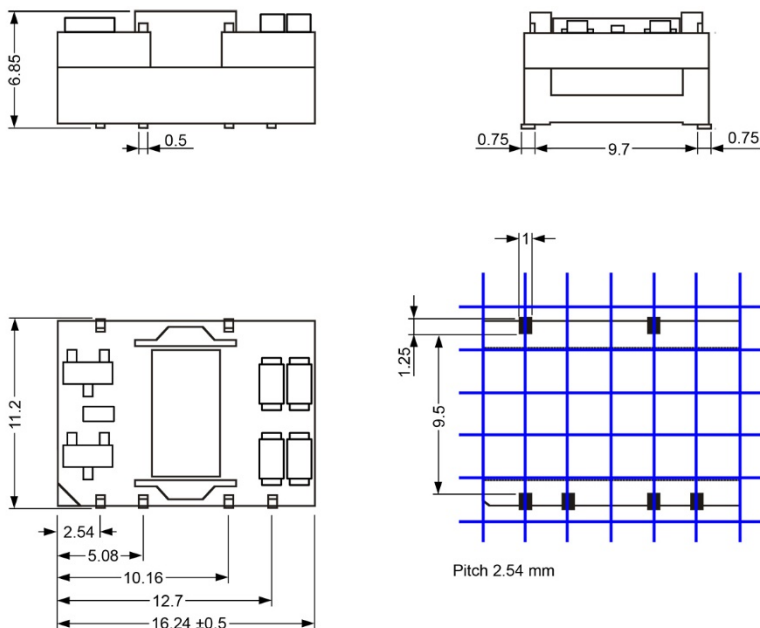

Assignment dual output	
Lead	Function
1	-Vinput
2	+Vinput
3	No Lead
4	Common
5	-Voutput
6	No Lead
7	+ Voutput
8	No Lead
9	No Lead
10	Not connected

All dimensions in mm  
General tolerances 0.25 mm

SMD10 packing units:  
Tube 30 pieces  
Tape & Reel 450 pieces

Mechanical dimensions tape 32 mm for SMD10 package

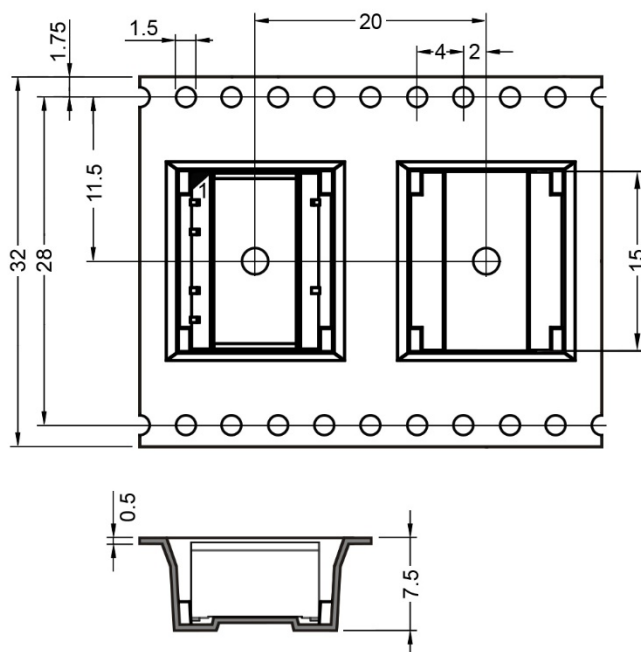

# 1 W DC-DC Converter P10S-Series

Mechanical dimensions reel 330 mm

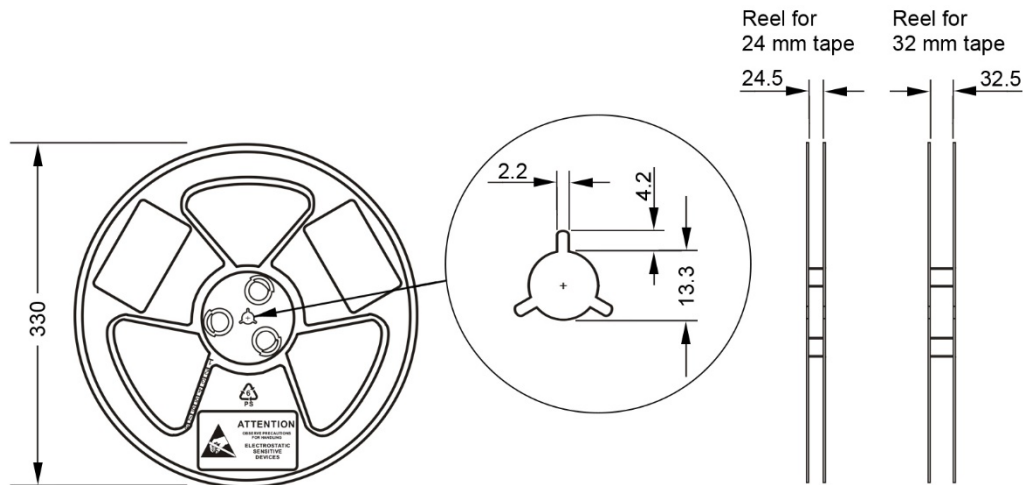

SMD8 on 24 mm tape, quantity 500 pieces per reel  
 SMD10 on 32 mm tape, quantity 450 pieces per reel

Mechanical dimensions reel tube 486 mm and 542 mm

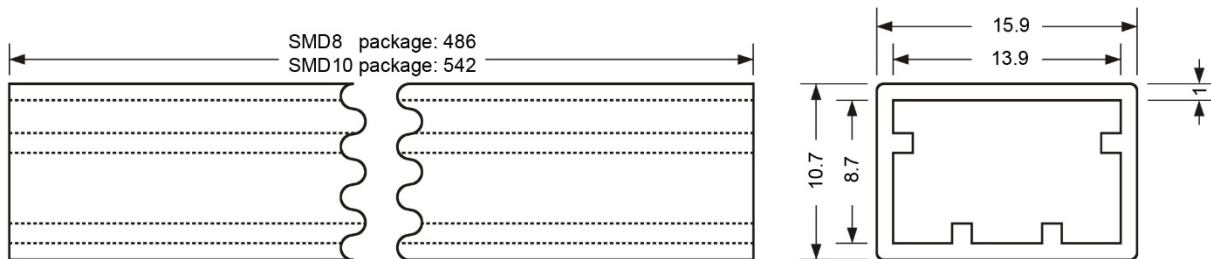

Dimensions in mm

SMD10 in 486 mm tube, quantity 30 pieces, dual output version  
 SMD8 in 542 mm tube, quantity 40 pieces, single output version

PHI-CON is a trademark of HY-LINE Holding GmbH.

Only for professional use by professionals! Not for resale or distribution to the general public in any way! Read the instructions carefully before using!

*Life Support Policy:* HY-LINE does not authorize the use of any of its products for use in life support devices or systems without the express written approval of an officer of the Company. Life support systems are devices which support or sustain life, and whose failure to perform, when properly used in accordance with instructions for use provided in the labeling, can be reasonably expected to result in significant injury to the user.

Rev: 20210317 f