

Container Tracking Antenna CTAZXM_WP

GSM 850 / 900 / 1800 / 1900 MHz + UMTS

Magnet Mount



- **GPS antenna for container tracking in sea containers**
- **Magnet mount antenna water proof IP65**
- **Worldwide usable**
- **The antenna is hidden inside the container, not visible from outside**
- **Including 868 MHz – services and DECT**
- **Our products are RoHS- and REACH-conform**



Technical Data

GPS

| | |
|-----------------|---|
| Frequency Range | 850/900/1800/1900 + 2100 MHz |
| VSWR* | < 2.0 typ. |
| Peak Gain* | -3 dBi typ. (900 MHz) +2 dBi typ. (1800 MHz) +2 dBi typ. (2100 MHz) |
| Power max. | 10 W |

* Measured with 0.6m cable on 30x30cm ground plane

Mechanical Data

| | |
|-----------------------|--|
| Dimensions (ØxH) | ca. 25 mm x 64 mm |
| Temperature Range | -40°C to +85°C (operating temperature) |
| Connection (Standard) | ca. 0.5m connecting cable RG174 with GSM/FME(f) Other cablelengths and connectors see ordering example and connector list in Internet |

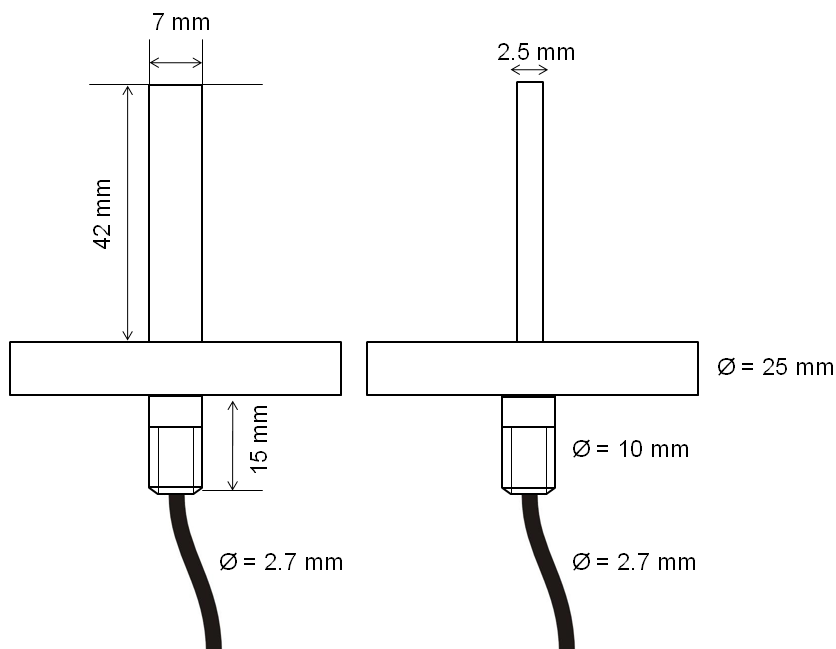

Radiation diagram (typ.)*

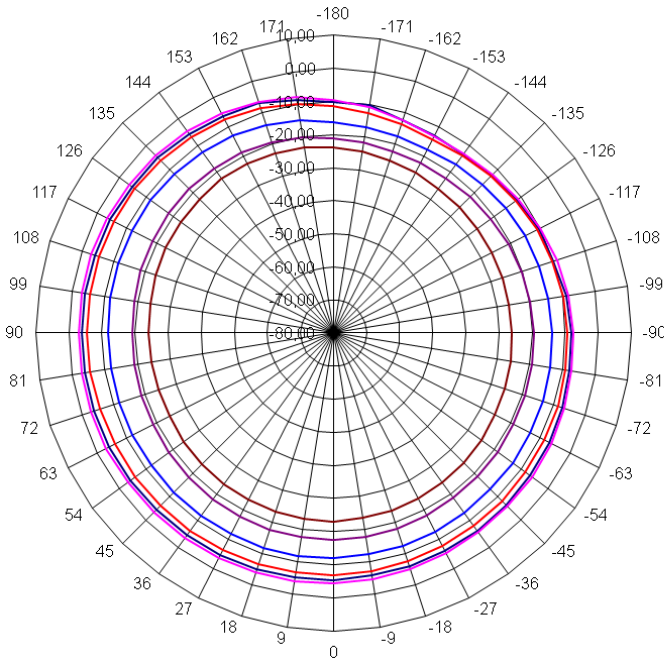

GSM 900 MHz
Peak Gain: -3 dBi

- 764,00
- 792,00
- 820,00
- 848,00
- 876,00
- 904,00

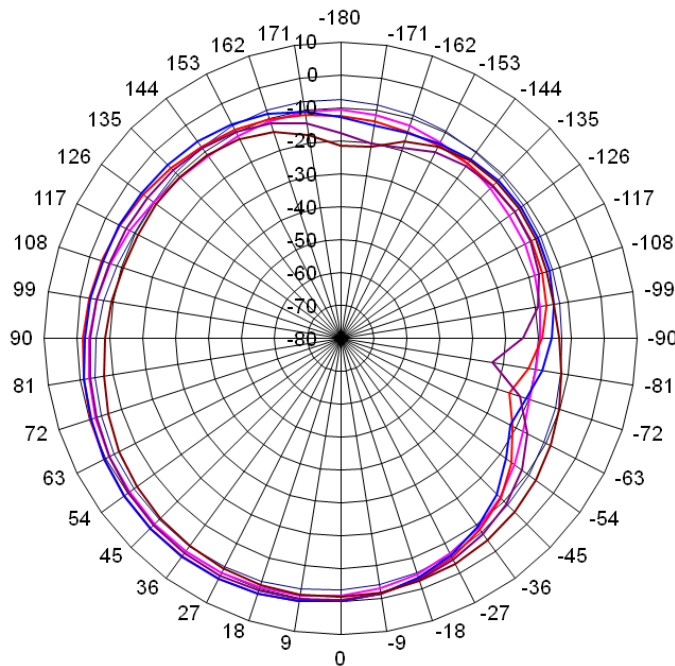

GSM 1800 MHz
Peak Gain: +2 dBi

- 1710
- 1788
- 1866
- 1944
- 2022
- 2100

GSM 2100 MHz
Peak Gain: +2 dBi

* Measured with 0.6m cable on 30x30cm ground plane

Ordering example

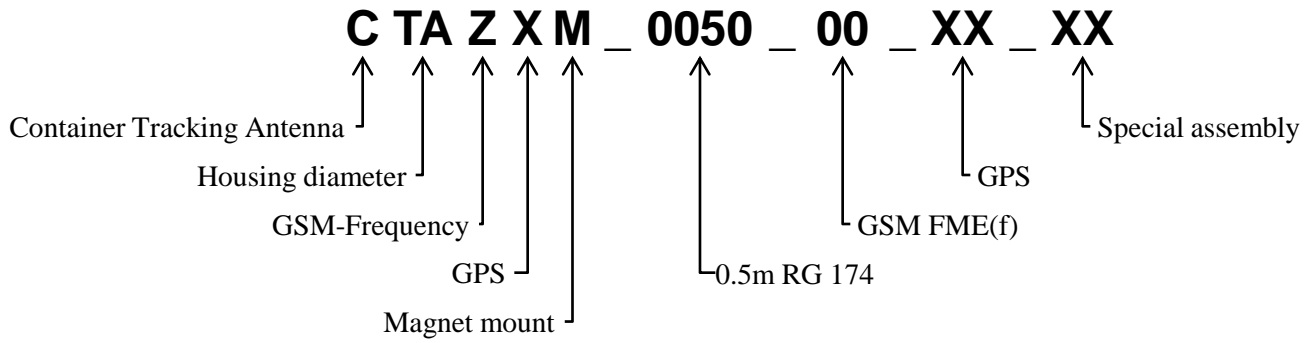

Warranty

The lawful warranty conditions apply.