

Multi channel 25kHz NBFM remote control TX/RX

The CXT transmitter and CXR receiver modules offer a multi channel, low power, and reliable remote control data link. This makes the CXT/CXR pair ideally suited to those low power applications where existing wideband modules have insufficient range, or where low cost multi-channel operation is needed without compromising on RF specification or regulatory requirement.



Figure 1: CXT2 transmitter and CXR2 receiver

Features

- Conforms to EN 300 220-3 and EN 301 489-3
- High performance double superhet. PLL synthesizer with TCXO
- SAW front-end filter
- Usable range over 1km
- 16 bit unit address (65535 unique addresses)
- Momentary and Latched outputs
- Fully screened. Low profile
- Re-programmable via RS232 interface
- Low power requirements

Applications

- Industrial telemetry and telecommand
- HVAC controls
- Wireless door entry systems
- Simple On/Off switching
- In-building environmental monitoring and control
- High-end security and fire alarms
- Heavy vehicle/machinery controls
- Status reporting and monitoring secure systems

Technical Summary

- Operating frequency: 173.200 - 173.325MHz (UK band)
 150.825 - 152.450MHz (Australian Band)
 433.875 - 434.650MHz (EU band)
 458.525 - 459.1MHz (UK band)
- Other custom VHF and UHF bands
- 32 channels @ 25kHz channel spacing
- Transmit power: +10dBm (10mW) / +20dBm (100mW)
- Supply range: 3.1 – 15V (TX @ 10mW and RX), 4.1 – 15V (TX @ 100mW)
- Current consumption: 34mA @ 10mW, 90mA @ 100mW (transmit) and 20mA (receive)
- Data bit rate: 5kbps max. (standard module)
- Receiver sensitivity: -118dBm (for 12 dB SINAD)
- Serial configuration by inverted RS232 at 3V CMOS level

Easy control functions with CXT and CXR:

There are certain user applications where a very simple 'on/off' control function is needed (for example: control of floodlights, alarm sounders, machine override shutdown). Normally such applications require a simple microprocessor or dedicated remote control chip to be added to the radio module, incurring extra size, cost and sometimes software overhead.

Not anymore. The CXT and CXR module pair (based on either LMT2/LMR2 (UHF version) or LMT1/LMR1 (VHF version)) includes a simple-to-use single function controller/actuator, implemented in the firmware of the radio's internal processor. This code allows the unit to be used as a very simple remote control product, with either a latched or a momentary output. No external control device is required.

Two inputs are provided on the CXT transmitter. Grounding input A sends a coded datastream to the CXR receiver which commands it to latch it's A output high (+3v). Grounding the transmitter B input sends a datastream which resets the receiver A pin to zero. Also, for the duration of the B transmission, the receiver B output is high. The minimum duration of a B output pulse is 300mS.

The CXT transmits whenever either A or B are low, but to function the TXE $\overline{\text{TXE}}$ must also be low (this can be tied low for simplicity, or diode 'or'ed with the A, B inputs to minimise current consumption)

The data format uses is a modified biphasic format with an average data rate of 600 bits per second. A 42 bit data burst is used (preceded by ample preamble). This incorporates a 16 bit unit address. This is easily modified via the 2400 baud serial communication port (SI pin), which allows both the unit address and the channel number (1 of 32 operating frequencies) to be easily modified. Commands are in an easy to understand 'ascii text and decimal numbers' form, simply entered by hand from any terminal program. Once programmed, values are stored in non-volatile memory.

MOMENTARY PUSH BUTTON OPERATION

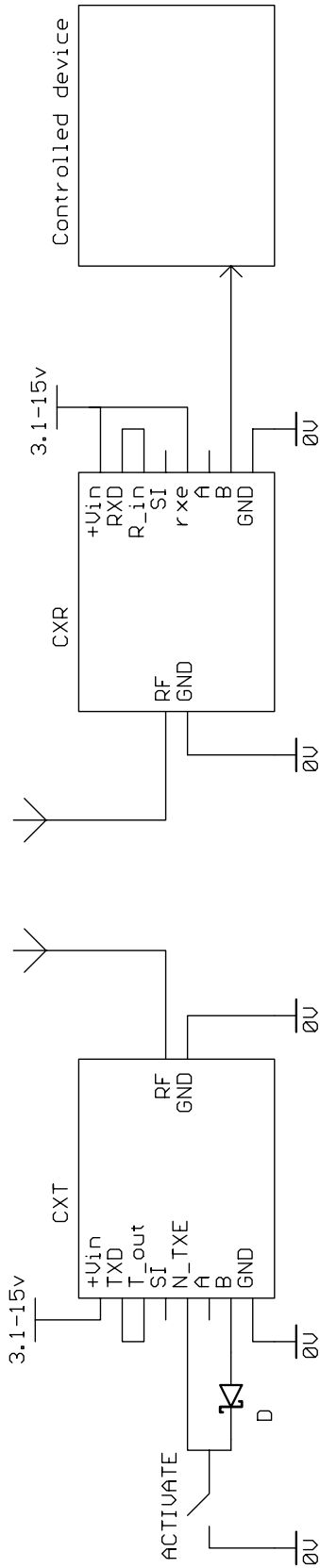

LATCHED <ON/OFF> OPERATION

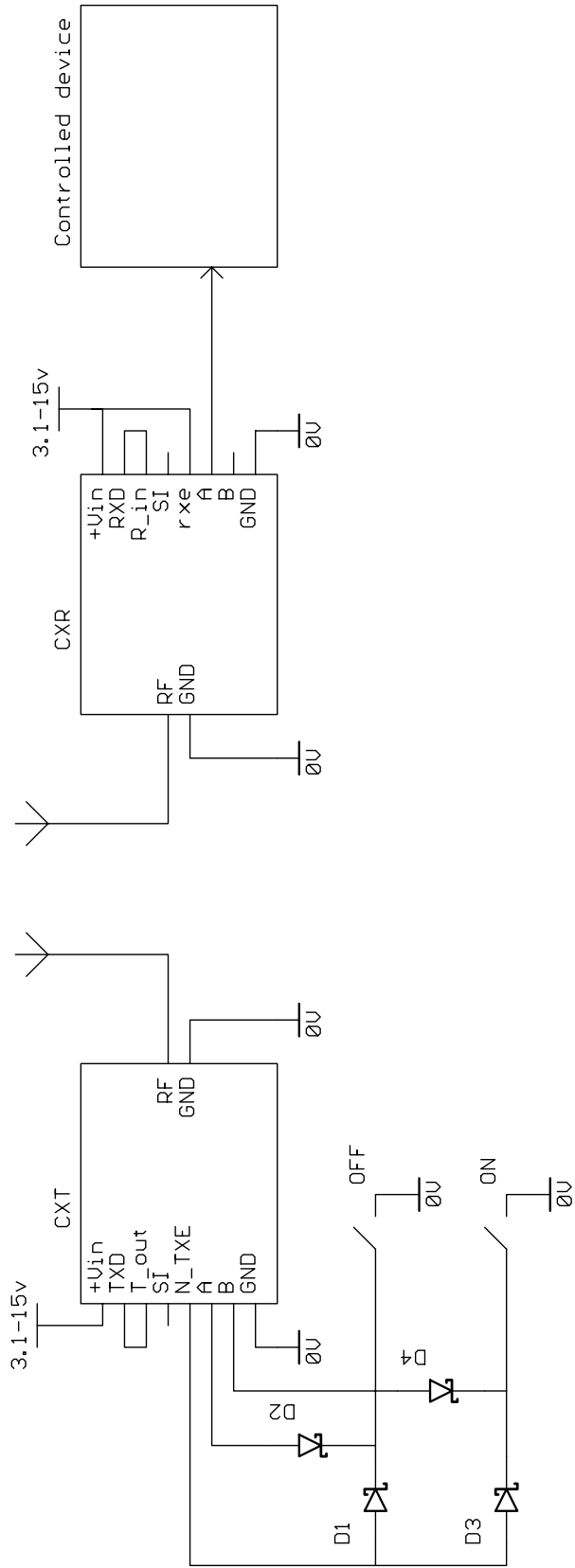

Figure 2: Application circuits

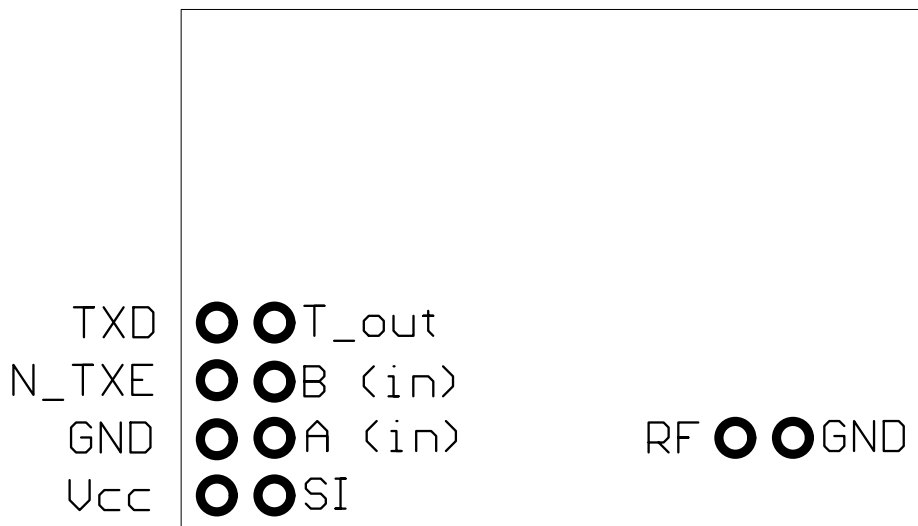

Figure 3: CXT footprint (top view)

Pin description –CXT

Pin	Name	Function
1a	Vcc	3.1 – 15V power supply
2a	0V	Ground
3a	N_TXE	Transmit Enable (active low)
4a	TXD	Link to 4b
1b	SI	Serial frequency programming / configuration ¹
2b	A (in)	Main (latching) input
3b	B (in)	Second (cancel) input
4b	T_out	Link to 4a

Notes:

1. Serial programming is by an inverted, CMOS logic level, 2400 baud RS232 datastream applied to the SI pin.
2. TXE has a 100kΩ pullup to Vcc
3. Do not exceed 3v logic levels on SI, A or B.
4. SI input has pullup (50K) to 3v internal rail.
5. A and B inputs have pullups (50K) to 3v internal rail. (A, B inputs: active low)
6. CX versions can be identified by the presence of C7, on the underside of the LMT series TX board



Figure 4: CXR footprint (top view)

Pin description –CXR

Pin	Name	Function
1a	Vcc	3.1 – 15V power supply
2a	0V	Ground
3a	RXE	Receiver Enable (active high)
4a	RXD	Link to 4b
5a	N/C (AF out)	No connection, 700mV p-p audio. DC coupled, approx 0.8v bias.
1b	SI	Serial frequency programming / configuration ¹
2b	A (out)	Main (latching) output
3b	B (out)	Secondary output
4b	R_in	Link to 4a
5b	RSSI	DC level between 0.5v and 2.2v. 60dB dynamic range

NOTES:

1. Serial programming is by an inverted, CMOS logic level, 2400 baud RS232 datastream applied to the SI pin.
2. Do not exceed 3v logic levels on SI, A or B.
3. SI input has pullup (50K) to 3v internal rail.
4. A and B outputs are 3v cmos, active high. Up to 5mA may be drawn from each
5. CX versions can be identified by the presence of C7, on the underside of the LMR series RX board

Condensed specifications

Frequency	433MHz EU, 458MHz / 173MHz UK and 151MHz Australian bands EU 433.875 - 434.65MHz UK: 458.525 - 459.1MHz 173.200 - 173.325MHz Australian: 150.825 - 152.450MHz <i>Other custom VHF and UHF bands</i>
<i>Frequency stability</i>	±1.5kHz
<i>Channel spacing</i>	25kHz
<i>Number of channels</i>	32 (controlled via RS232 interface)
Operating temperature	-20 °C to +55 °C (Storage -30 °C to +70 °C)
Spurious radiations	Compliant with ETSI EN 300 220-3 and EN 301 489-3
Transmitter	
Output power	+10dBm (10mW) ±1dB (factory adjustable 1 - 25mW) +20dBm (100mW) ±1dB (factory adjustable 25 - 100mW)
Peak deviation	±3kHz
Modulation type	2.5kbps FSK (biphase) data stream
TX modulation bandwidth	DC – 5kHz (3V CMOS compatible)
Adjacent channel TX power	<-37dBm
TX spurious	<-45dBm (no output in Standby)
Supply	
<i>Voltage</i>	3.1V – 15V (1-25mW) 4.1 – 15V (25 – 100mW)
<i>Current</i>	35mA @ 10mW (nominal) 65mA @ 50mW (nominal) 100mA @ 100mW (nominal) <9µA standby (TXE high or floating)
Inputs	data (CMOS/TTL compatible)
Size	33 x 23 x 9mm (BiM sized footprint, new pinout)
Interface <i>User</i>	10 (8) pin 0.1" pitch dual row (5+5 or 4+4) header
<i>RF</i>	2pin 0.1" pitch
Recommended PCB hole size	1.2mm
Receiver	
Sensitivity	-115dBm for <0.1% data errors)
AF bandwidth (-3dB)	4kHz
image	<-60db
spuri / adjacent channel	<-65db
blocking	- 84dB
LO re-radiation	-60dBm
Auxiliary outputs	RSSI, audio
Supply	
<i>Voltage</i>	3.1V – 15V
<i>Current</i>	20mA receive <1µA standby (RXE low)
Size	46 x 23 x 9mm
Interface <i>User</i>	10 pin 0.1" pitch dual row (5+5) header
<i>RF</i>	2pin 0.1" pitch
Recommended PCB hole size	1.2mm

Programming the CXT and CXR

A 2400 baud cmos level 'inverted RS232 format' (1 start bit, 8 data, 1 or 2 stop bits, no parity) is used.

These units employ a sub-set of the programming commands used by standard LMT/LMR modules. In addition, the command AVALUE is used to set the address number.

As the SI pin is dedicated to serial communication only, the 'ENABLESERIALMODE' command string is NOT required.

To successfully program the unit it must be in active state (RXE high, or TXE low), so provision should be made to force the unit into this state while programming (either a jumper, or a third pin on the programming connector, could be used).

GOCHAN aa	Serially select channel aa, where aa is ch0 to ch31
AVALUE bbbbb	Set value for unit address
LOAD aa nnnnn	Set value of N register for channel aa, where aa is Channels 0 to 31
RVALUE rrrr	Set value for R register
<cr>	Process entry
/	Clear all buffers

aa = a two digit channel number from 00 to 31

nnnnn = synthesizer N register value (up to 65535)

rrrr = synthesizer R register value (up to 16383)

bbbbbb = unit address (up to 65535)

$$CXT = N_{TX} = \frac{f_{RF}}{f_{Channelspacing}} = \frac{433.900MHz}{25kHz} = 17356 \qquad R = \frac{f_{TCXO}}{f_{channelspacing}} = \frac{13MHz}{25kHz}, \text{ So } R=520$$

VHF CXT units have 10MHz, not 13MHz reference oscillators:

$$R = \frac{f_{TCXO}}{f_{channelspacing}} = \frac{10MHz}{25kHz}, \text{ So } R=400 \text{ (for VHF CXT)}$$

$$CXR = N_{RX} = \frac{f_{RF} - 21.4MHz}{f_{Channelspacing}} = \frac{433.900MHz - 21.4}{25kHz} = 16500$$

Note: A pause of at least 50ms must be allowed between command strings (EEPROM programming time).

SERIAL PROGRAMMING CONNECTIONS

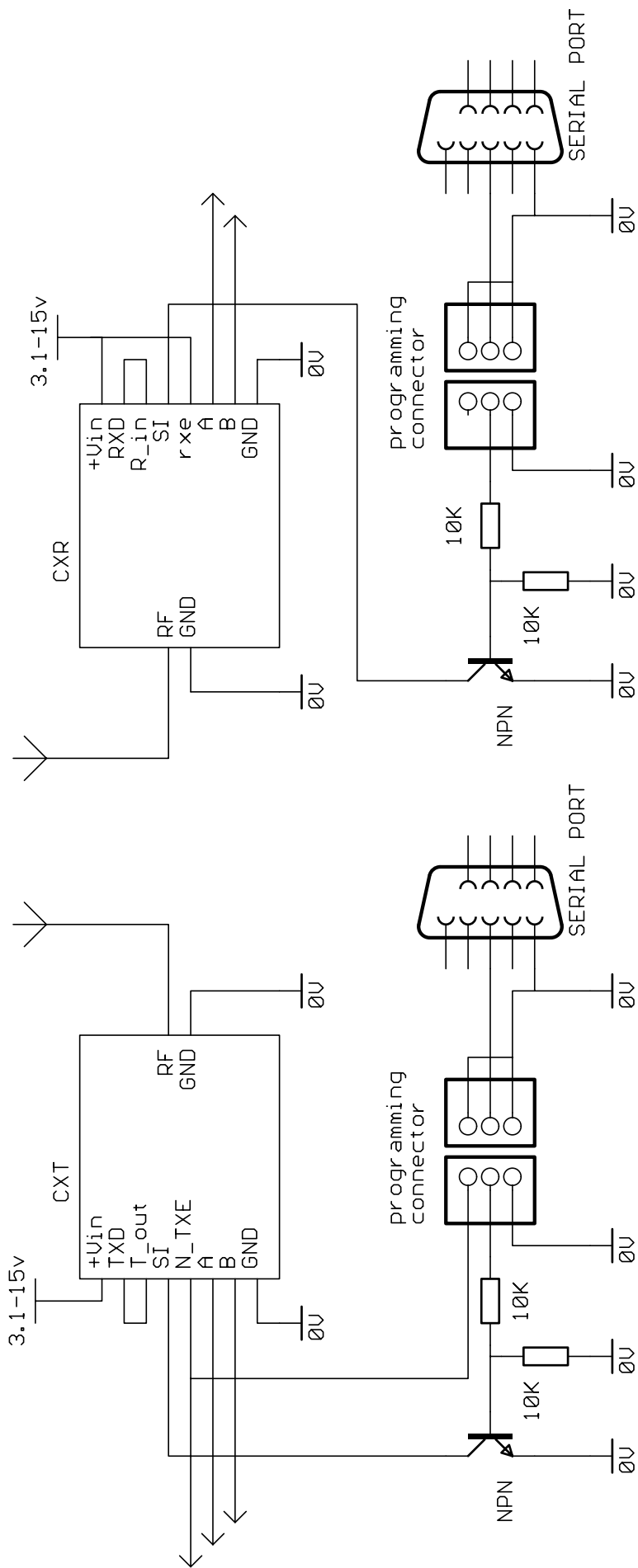

Figure 5: Serial programming interface

RX Received Signal Strength Indicator (RSSI)

The CXR has wide range RSSI that measures the strength of an incoming signal over a range of 60dB or more. This allows assessment of link quality and available margin and is useful when performing range tests.

The output on pin 5b of the module has a standing DC bias of up to 0.5V with no signal, rising to 2.5V at maximum indication (RF input levels of -40dBm and above). $\Delta V_{min-max}$ is typically 2V and is largely independent of standing bias variations. Output impedance is 40k Ω . Pin 5b can drive a 100 μ A meter directly, for simple monitoring.

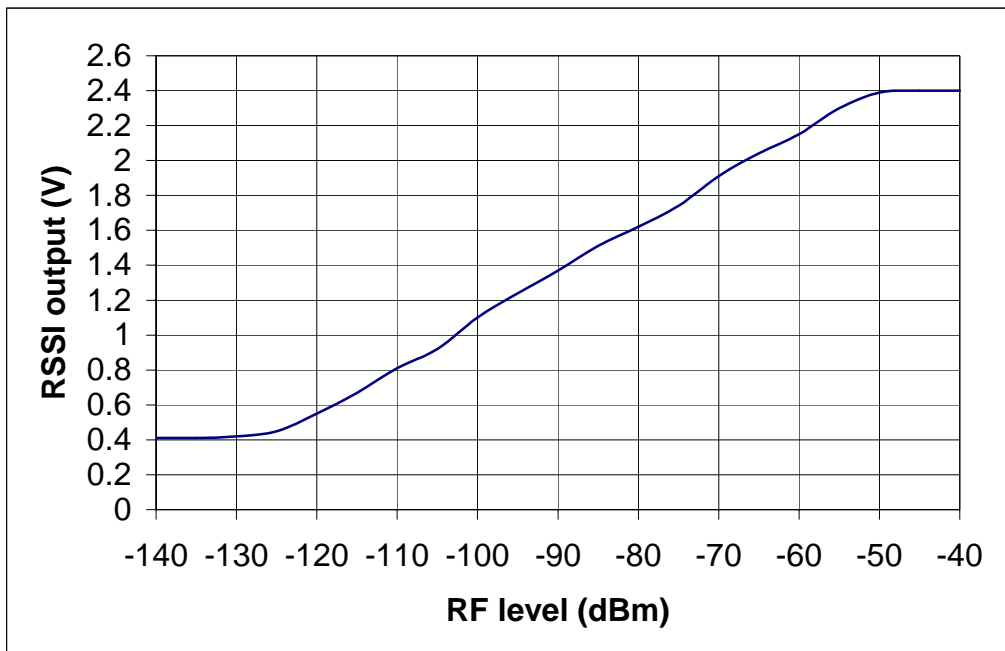

Figure 6: typical RSSI level with respect to received RF level at CXR antenna pin

Antenna requirements

Three types of integral antenna are recommended and approved for use with the module:

- A) **Whip** This is a wire, rod ,PCB track or combination connected directly to RF pin of the module. Optimum total length is 16.4cm (1/4 wave @ 433MHz). Keep the open circuit (hot) end well away from metal components to prevent serious de-tuning. Whips are ground plane sensitive and will benefit from internal 1/4 wave earthed radial(s) if the product is small and plastic cased
- B) **Helical** Wire coil, connected directly to RF pin, open circuit at other end. This antenna is very efficient given it's small size (20mm x 4mm dia.). The helical is a high Q antenna, trim the wire length or expand the coil for optimum results. The helical de-tunes badly with proximity to other conductive objects.
- C) **Loop** A loop of PCB track tuned by a fixed or variable capacitor to ground at the 'hot' end and fed from RF pin at a point 20% from the ground end. Loops have high immunity to proximity de-tuning.

	A	B	C
	<i>whip</i>	<i>helical</i>	<i>loop</i>
Ultimate performance	***	**	*
Easy of design set-up	***	**	*
Size	*	***	**
Immunity proximity effects	*	**	***
Range open ground to similar antenna	500m	200	100

The antenna choice and position directly controls the system range. Keep it clear of other metal in the system, particularly the 'hot' end. The best position by far, is sticking out the top of the product. This is often not desirable for practical/ergonomic reasons thus a compromise may need to be reached. If an internal antenna must be used, try to keep it away from other metal components, particularly large ones like transformers, batteries and PCB tracks/earth plane. The space around the antenna is as important as the antenna itself.

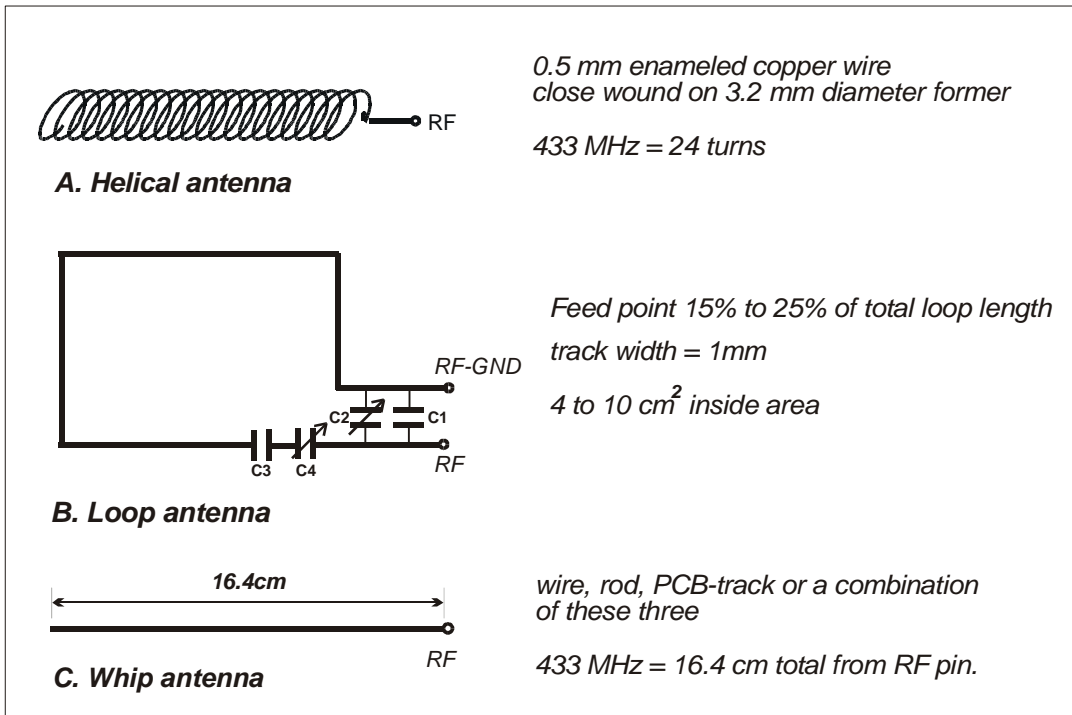

Figure 7: Antenna types (433MHz version)

Ordering Information:

Part No.	Description	Frequency band (MHz)	Supply (V)	RF power (mW)
VHF				
CXT1-173-1	Transmitter	173.200 - 173.325	3.1 -15	10
CXR1-173-1	Receiver	173.200 - 173.325	3.1 -15	
CXT1-151-1	Transmitter	150.825 - 152.450	4.1 -15	100
CXR1-151-1	Receiver	150.825 - 152.450	3.1 -15	
UHF				
CXT2-433-1	Transmitter	433.875-434.650	3.1 -15	10
CXR2-433-1	Receiver	433.875-434.650	3.1 -15	
CXT2-458-1	Transmitter	458.525 - 459.1	4.1 -15	100
CXR2-458-1	Receiver	458.525 - 459.1	3.1 -15	

Notes:

1. CXT/CXR are available on number of other VHF and UHF frequencies. Other UHF band frequencies are subject to SAW filter availability. e.g. 315, 419, 429, 448, 465MHz etc

APPENDIX:

CXT2-433-1 & CXR2-433-1 Demo boards



Radiometrix Ltd

Hartcran House
231 Kenton Lane
Harrow, Middlesex
HA3 8RP
ENGLAND

Tel: +44 (0) 20 8909 9595

Fax: +44 (0) 20 8909 2233

sales@radiometrix.com

www.radiometrix.com

Copyright notice

This product data sheet is the original work and copyrighted property of Radiometrix Ltd. Reproduction in whole or in part must give clear acknowledgement to the copyright owner.

Limitation of liability

The information furnished by Radiometrix Ltd is believed to be accurate and reliable. Radiometrix Ltd reserves the right to make changes or improvements in the design, specification or manufacture of its subassembly products without notice. Radiometrix Ltd does not assume any liability arising from the application or use of any product or circuit described herein, nor for any infringements of patents or other rights of third parties which may result from the use of its products. This data sheet neither states nor implies warranty of any kind, including fitness for any particular application. These radio devices may be subject to radio interference and may not function as intended if interference is present. We do NOT recommend their use for life critical applications.

The Intrastat commodity code for all our wireless modules is: 8542 6000.

R&TTE Directive

After 7 April 2001 the manufacturer can only place finished product on the market under the provisions of the R&TTE Directive. Equipment within the scope of the R&TTE Directive may demonstrate compliance to the essential requirements specified in Article 3 of the Directive, as appropriate to the particular equipment.

Further details are available on The Office of Communications (Ofcom) web site:

<http://www.ofcom.org.uk/radiocomms/ifi/>

Information Requests

Ofcom

Riverside House

2a Southwark Bridge Road

London SE1 9HA

Tel: +44 (0)845 456 3000 or 020 7981 3040

Fax: +44 (0)20 7783 4033

information.requests@ofcom.org.uk

European Radiocommunications Office (ERO)

Peblingehus

Nansensgade 19

DK 1366 Copenhagen

Tel. +45 33896300

Fax +45 33896330

ero@ero.dk

www.ero.dk
