



The Laird Connectivity FlexNotch is the only adhesive-backed, flexible notch antenna that can be easily custom-trimmed for maximum range within a specific enclosure. Paired with the antenna design expertise offered by Laird, FlexNotch provides a simple, repeatable process for optimizing antenna tuning to deliver maximum range for your application.

FEATURES AND BENEFITS

- Can be installed on flat or curved surfaces
- Simple custom options with trimming length
- Quick and easy installation
- Flexible, ultra-low profile
- RoHS-compliant
- Adhesive holds to surface during humidity exposure and hot/cold cycles

ELECTRICAL SPECIFICATIONS	
Operating Frequency (MHz)	2400 - 2480
Peak Gain (dBi)	2.0
Average Gain (dBi)	> -1.6
VSWR	< 2.5:1
Nominal Impedance (Ohms)	50
Polarization	Linear
Azimuth Beam Width	

MECHANICAL SPECIFICATIONS	
Dimensions – mm (in.)	32.0 x 21.08 (1.26 x 0.83)
Weight – g (oz.)	0.85 (0.03)
Antenna Color	Clear yellow
Adhesive	3M 100 MP
Connector Height (max) – mm (in.)	MHF1 (U.FL): 2.5 (0.098) MHF4L: 1.4 (0.055)

ENVIRONMENTAL SPECIFICATIONS	
Operating Temperature – °C (°F)	-40°C to +85°C (-40°F to +185°F)
Material Substance Compliance	RoHS Compliant

ORDERING INFORMATION

PART NUMBER	DESCRIPTION
001-0015	2.4 GHz FlexNotch antenna with U.FL cable, 100 mm
001-0023	2.4 GHz FlexNotch antenna with MHF4L cable, 100 mm

MECHANICAL DRAWING

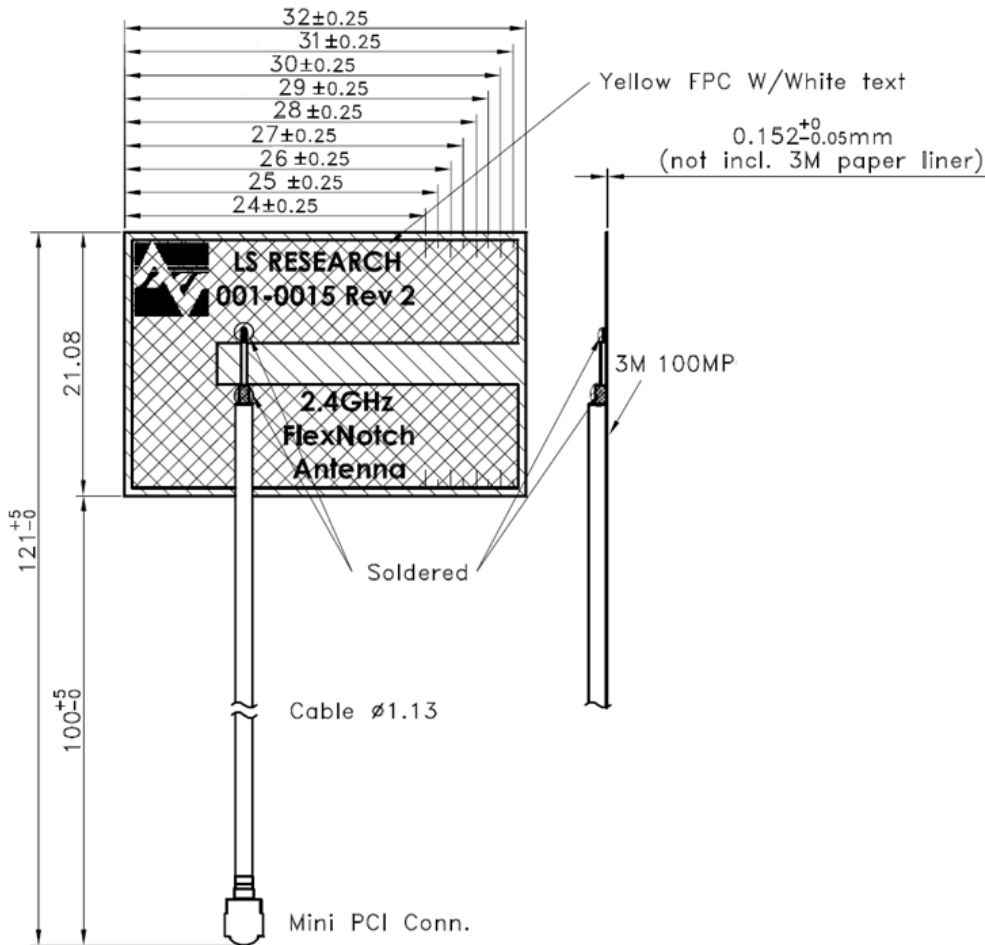

Figure 1: FlexNotch mechanical drawing

ANTENNA TESTING

Test Setup

Antenna measurements such as VSWR were measured with an Agilent E5071C Vector Network Analyzer. Radiation patterns were measured with an Agilent 5181A Signal Generator and Agilent E4445A Spectrum Analyzer in a three-meter anechoic chamber.

Flat surface measurements were done with the antenna centered on a 1.5-millimeter thick plate of Polycarbonate.

Flat Surface Antenna Measurements

VSWR

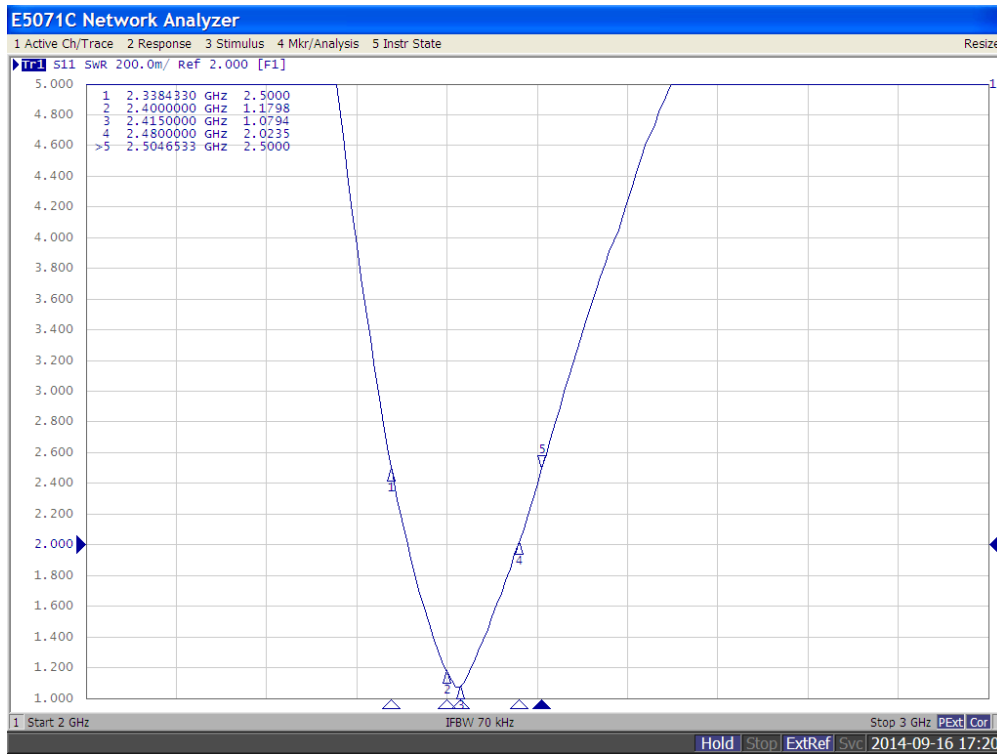

Figure 2: Antenna VSWR measured on a 1.5 mm thick plate of polycarbonate

Flat Surface Antenna Radiation Performance

FlexNotch antenna centered on a 1.5 mm thick plate of polycarbonate

Antenna Measurement Set-Up – Horizontal Orientation

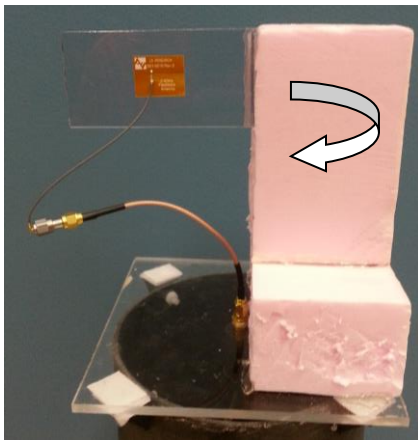

Figure 3: Horizontal orientation measurement

Horizontal Orientation at 2440 MHz

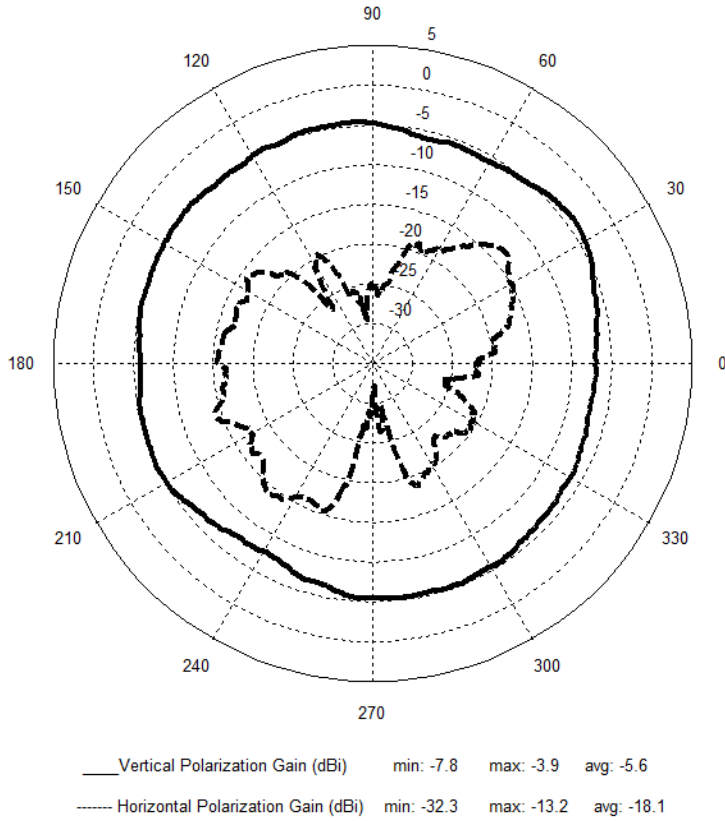

Figure 4: Horizontal orientation pattern

Antenna Measurement Set-Up – Vertical Orientation

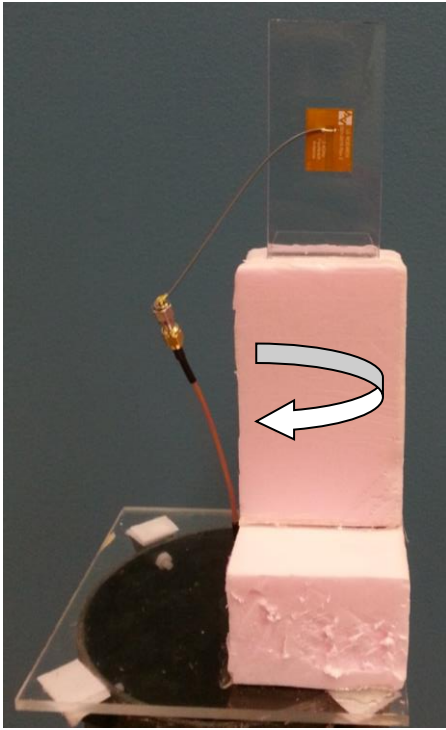

Figure 5: Vertical orientation measurement

Vertical Orientation at 2440 MHz

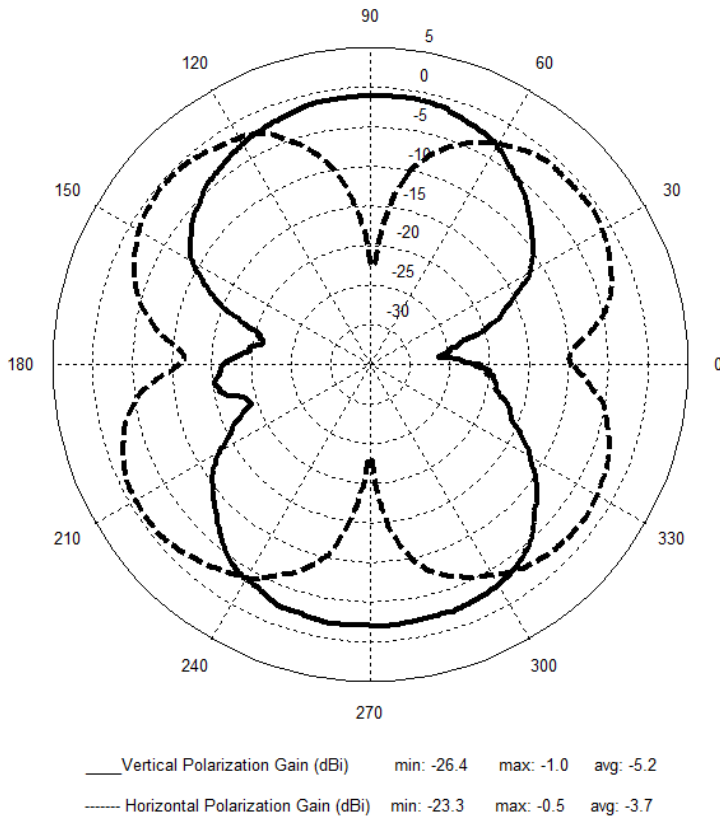

Figure 6: Vertical orientation pattern

Antenna Measurement Set-Up – Flat Orientation

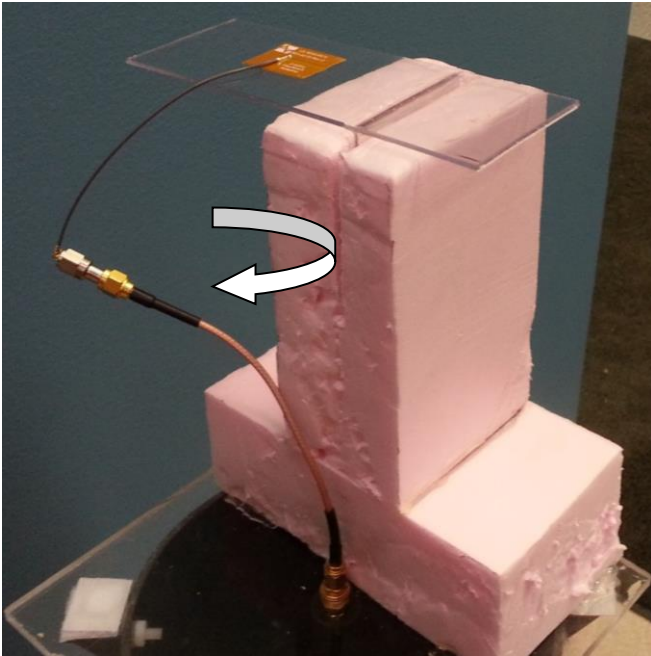

Figure 7: Flat orientation measurement

Flat Orientation at 2440 MHz

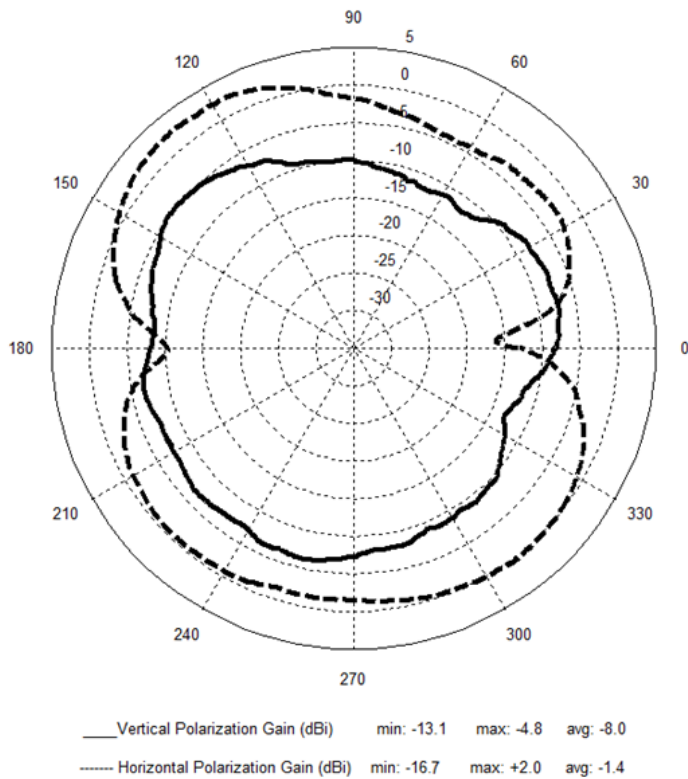

Figure 8: Flat orientation pattern

OPTIMAL INSTALLATION GUIDE

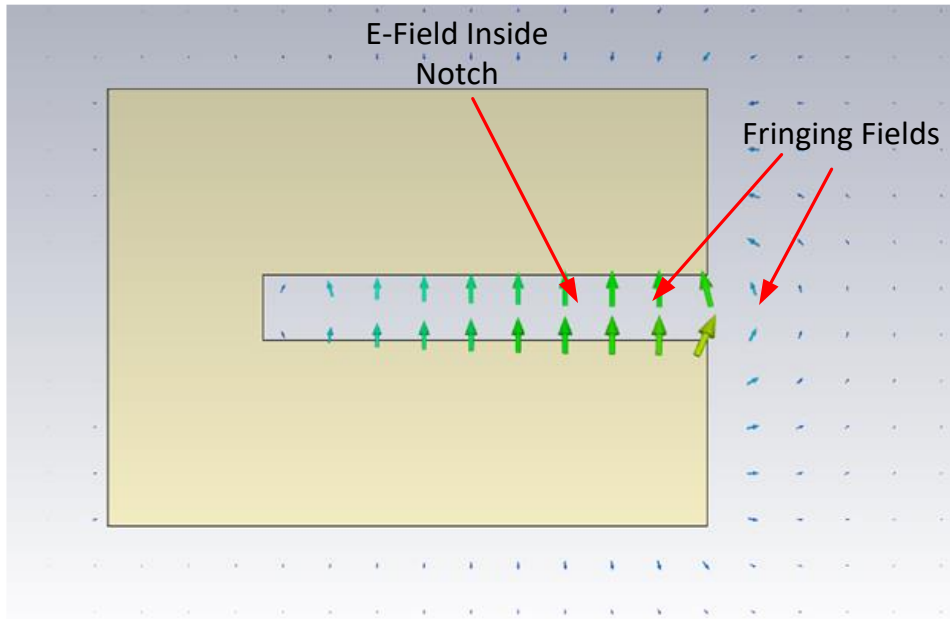

Figure 9: E-field radiation from FlexNotch; taken from CST simulation

The FlexNotch should be kept clear of any non-metal objects (such as plastics) on top of it by at least 5 mm (see [Figure 10](#)). Similarly, all four sides of the FlexNotch should be kept clear of any non-metal object by at least one millimeter (See [Figures 11-14](#)). Mounting the FlexNotch in a situation that does not allow for these clearance recommendations may change the gain characteristics stated in the datasheet, which could impact overall range of the wireless system.

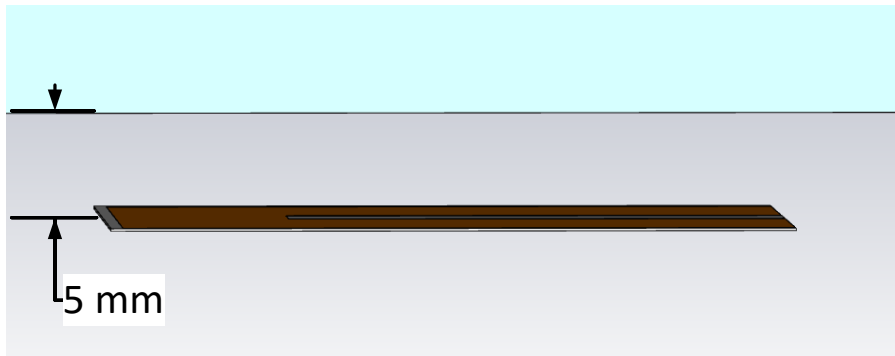

Figure 10: Above FlexNotch clearance

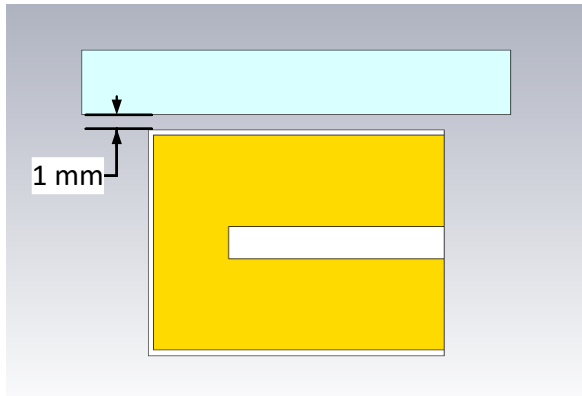

Figure 11: Top clearance

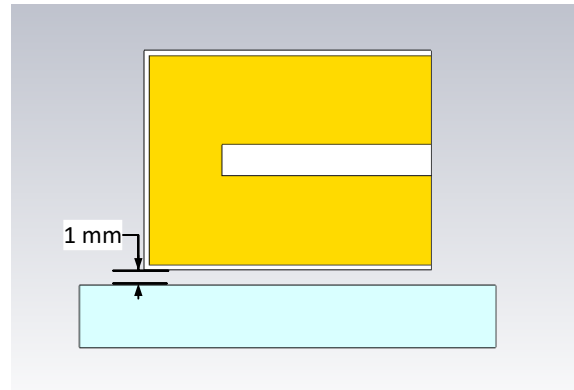

Figure 12: Bottom clearance

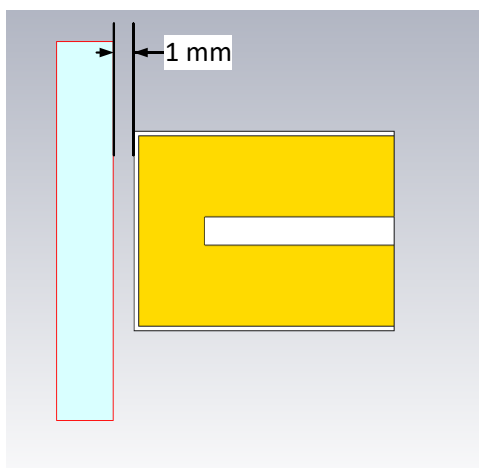

Figure 13: Left 'Cold' Side Clearance

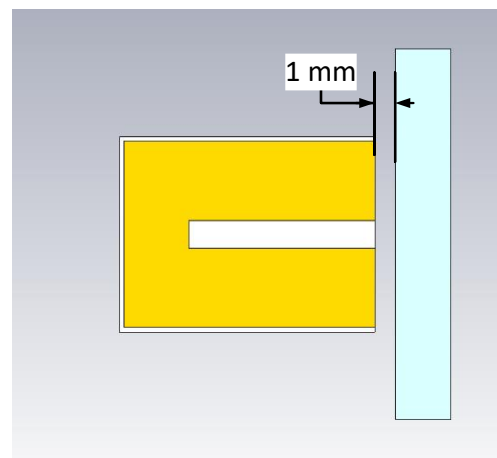
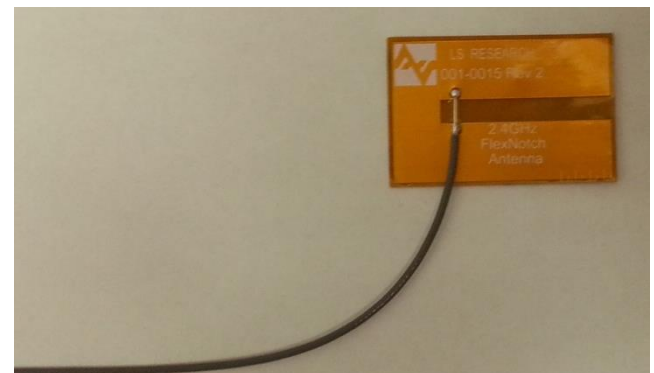
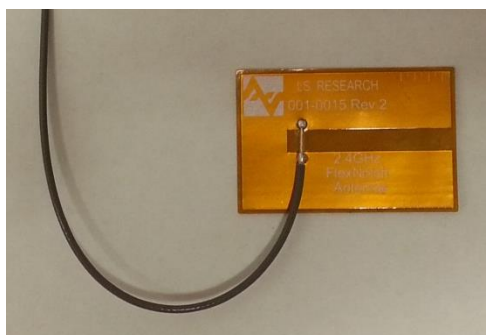

Figure 14: Open Side Clearance

The ideal material on which to mount the FlexNotch for maximum performance is 1.5-millimeter-thick polycarbonate. If the FlexNotch is mounted on a different material, the tuning will change which could cause a decrease in performance. Laird Connectivity can retune the FlexNotch for specific implementations and different materials on request.

The coaxial cable feeding the FlexNotch should be routed away from the antenna. Do not run the coaxial cable above the FlexNotch or near the open end of the notch. The cable should be routed perpendicular to the side of the FlexNotch (this is the way the cable comes assembled), around the cold side, or away from the ground wall. All three of these options are shown in **Figures 11-14**.



*Perpendicular to the side**Around the 'Cold' Side**Away from the Notch wall***Figure 15: Recommended cable routing**

As with any antenna, do not place conductive materials or objects near the antenna. The radiated fields from the antenna induce currents on the conductive surface which results in those currents producing their own radiation. These re-radiating fields from the metal will interfere with the fields radiating from the FlexNotch (this is true for any antenna). Other objects, such as an LCD display, placed in close proximity to the antenna may not affect its tuning but it can distort the radiation pattern. Materials that absorb electromagnetic fields should be kept away from the antenna to maximize performance. The following are common things to keep in mind when placing the antenna:

- Wire routing
- Speakers – These generate magnetic fields
- Metal chassis and frames
- Battery location
- Proximity to human body
- Display screen – These absorb radiation
- Paint – Do not use metallic coating or flakes

Flex Limits of the FlexNotch

One of the unique features of the FlexNotch is its ability to flex. However, due to the adhesive there are limits as to how much the antenna can be flexed and remain secured to the device. The FlexNotch should not be flexed in a convex position with a radius less than 16 millimeters. Going smaller than this may result in the antenna peeling off the surface over time. Should a tighter radius of curvature be required, we recommend that you contact Laird Connectivity for assistance.

**Figure 16: Convex-mounted**

The FlexNotch should not be flexed in a concave position with a radius less than 16 millimeters. Similar to the restrictions on the convex position, there is potential for the adhesive to peel off over time if the FlexNotch is bent beyond a 16-millimeter radius. If a tighter radius of curvature is required, we recommend that you contact Laird Connectivity for assistance. The FlexNotch is not designed to be twisted or crumpled. The adhesive back should lay flush with the surface on which it is mounted.

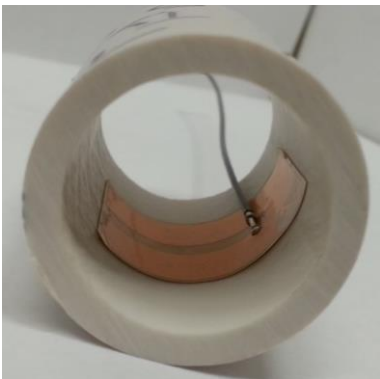
**Figure 17: Concave-mounted**

Mounting on Metal and Body Loaded Applications

The FlexNotch can tolerate being near conductive surfaces. A one-millimeter clearance should be observed between the top, bottom, and cold sides of the FlexNotch from any metal (see Figures 11-14). Metal should be kept away from the open end of the FlexNotch by at least 10 millimeters. However, any metal in close proximity to the open end will disrupt the radiation pattern and could cause a decrease in antenna gain.

Keep any metal above the FlexNotch away by at least 10 millimeters to prevent the antenna from detuning. However, this still causes some distortion of the radiation pattern.

Note: Do NOT mount the FlexNotch on a metal surface.

These same guidelines also apply to body worn applications.

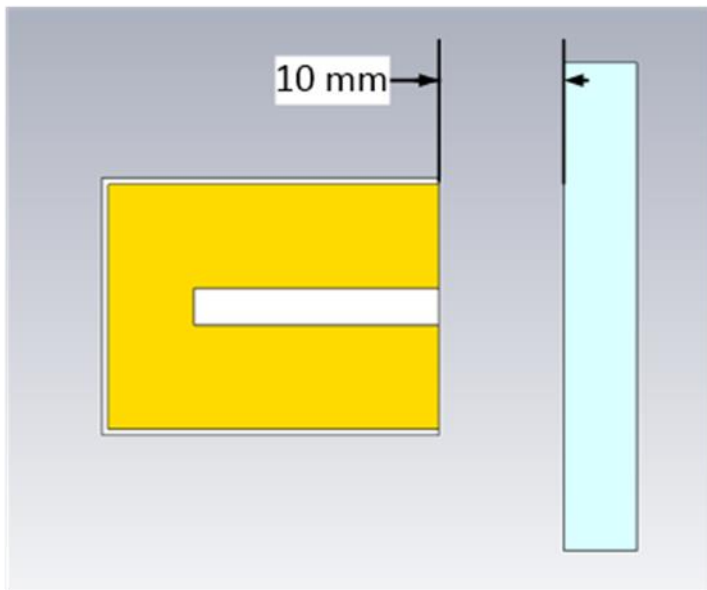

Figure 18: Open side metal clearance

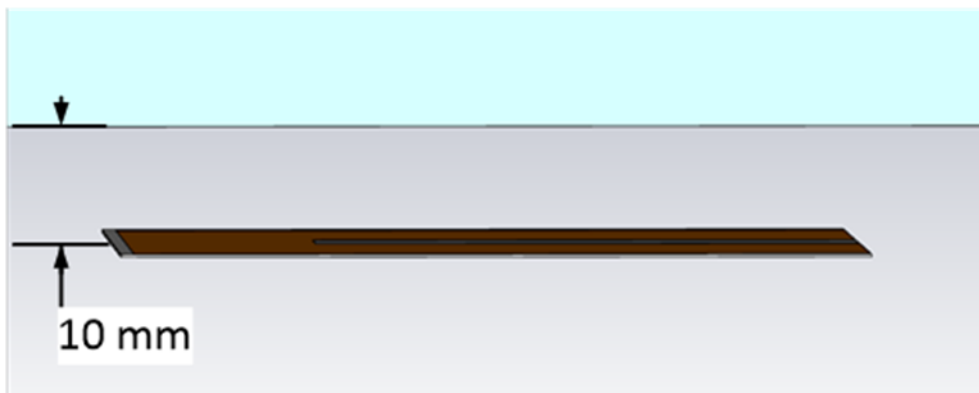

Figure 19: Above notch metal clearance

CUSTOMER-SPECIFIC TUNING

Laird Connectivity can assist with custom tuning of the antenna for your specific end product. Simply send Laird a sample of your enclosure or platform and we will tune an antenna for you. We will then send the results back indicating to which trim mark the antenna should be cut to optimize performance. You then trim the antenna to the indicated hash mark and stick it to your product at the time of assembly.

PRODUCT REVISION HISTORY

001-0015 (U.FL Connector)

Rev 1: Initial Production Release



Rev 2: Added Cut Hash Marks in intervals of 1 mm (Small Mark) and 2 mm (Large Mark)

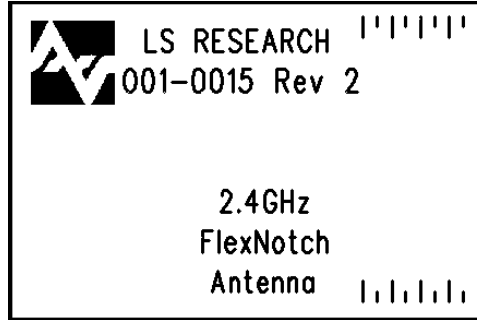

Rev 3: Changed Supplier – Color Change to Antenna

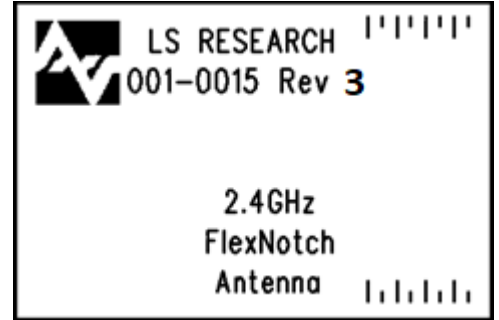

001-0023 (MHF4L Connector)

Rev 1: Initial Production Release

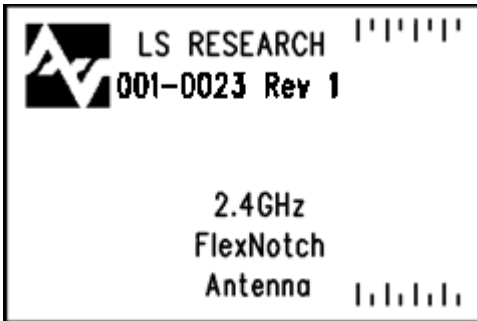

Rev 2: Changed Supplier – Color Change to Antenna

